

# static control made **Easy** IQ Easy system

## What is our IQ Easy system?

The Simco-ION IQ Easy platform is **the only smart system worldwide for controlling electrostatic** during your process. It has a central position in your machine. The IQ Easy platform enables:

- Standardised quality control
- Safety and convenience features
- Pro-active ionisation control

Carefree processes through smart devices that tell you when action is needed and can even solve efficiency issues by themselves through closed-loop feedback. The Smart SLC manages these processes and links the devices.

IQ software is built into almost all our products, our ionisation bars, sensors, charging devices and even our ATEX approved products have IQ compatibility. Our IQ products can be linked together with a Smart SLC or Manager IQ Easy, which function as the heart of the system. With the Smart SLC and Addition SLC's, control of up to 84 devices is possible. The IQ Easy system with compatible IQ devices enables:

- Live monitoring of all IQ devices
- Live adjusting of all IQ devices
- IQ devices can be switched on and off remotely
- Live efficiency data, with notifications when to clean an IQ device
- Logging of all data from the whole static control system

**In short:** Manage all your IQ devices real-time. The IQ devices solve efficiency issues through closed-loop feedback, or alert you when action is needed. Carefree static control in your process.

## Why IQ?

It is the smart way of controlling electrostatic, where **our products do the work for you and the IQ Easy system shows you when action is necessary**. Safety is enhanced, preventing explosions or fires in your machine originating from electrostatic charges and preventing shocks to employees. The devices tell you when they need cleaning, and whether they run efficiently. Closed-loop feedback can be enabled to have a smooth process where the required static charge is met.

**In short:** Safety through risk-control. Efficiency. Quality control.

## Product specifications

IQ Easy platform  
Power units



## Smart SLC IQ 4

Like our Manager IQ Easy, the Smart SLC controls our IQ compatible ionisation and measuring products. The Smart SLC has no embedded screen and can be integrated in the HMI of your machine. The configuration can be done by laptop locally or anywhere in the company network through a browser independent, web based interface. Ideal for process operators and machine builders who want to use their own preferred HMI.

Ethernet connections ensure a significant speed boost compared to the Manager IQ Easy 2.0. Use your PLC through Fieldbus, with real-time management of all connected devices. The Smart SLC can be linked with up to 13 Addition SLC's. The Addition SLC's can in turn control up to 6 device like our bars and sensors, with control of up to 84 devices simultaneously. Communication options through Fieldbus, external web based user interface and I/O make make it versatile in its use. You decide where you use the interface, on the HMI of your machine, laptop or PC.

### Pro-active ionisation control

With the IQ Easy system's Closed-Loop-Feedback, an optimal ionisation control is guaranteed. With bars and sensor connected to the IQ system, the web voltage can be actively controlled, ensuring a low residual charge. With charging applications a pre-defined charge can be set into the Smart SLC, ensuring the required charge on the web.

### Safety and convenience

The Smart SLC and corresponding devices have separated power inputs. The user interface remains active, while devices can be turned off for safety or maintenance reasons.

### Smart SLC in a nutshell

The only IQ system worldwide with closed-loop feedback and efficiency and cleaning indications for a carefree production process, managed on your own machine HMI or even managed remotely. With up to 84 IQ devices and real-time monitoring of all data.

### Features

- |  |   |
|--|---|
| • Significant speed through internal ethernet                                | • Ethernet for a complete user interface  |
| • Separated high voltage supply of SLC and connected devices, safety feature | • Browser independent   |
| • DIN rail mounting  | • Insight in log data   |
| • Plug & play device connection  | • Multiple closed-loop feedback possible with sensors, bars and charging generators |
| • Connect up to 6 devices per SLC  | • Object orientated user interface  |
| • Control up to 84 devices with Addition SLC's                               | • *Optional WLAN user interface   |
| • Digital inputs and outputs   | • *Optional WLAN Smart SLC to Addition SLC  |
| • Several fieldbus interfaces  |   |

\*Functionality in development. to be released

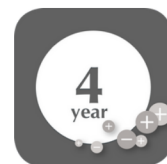

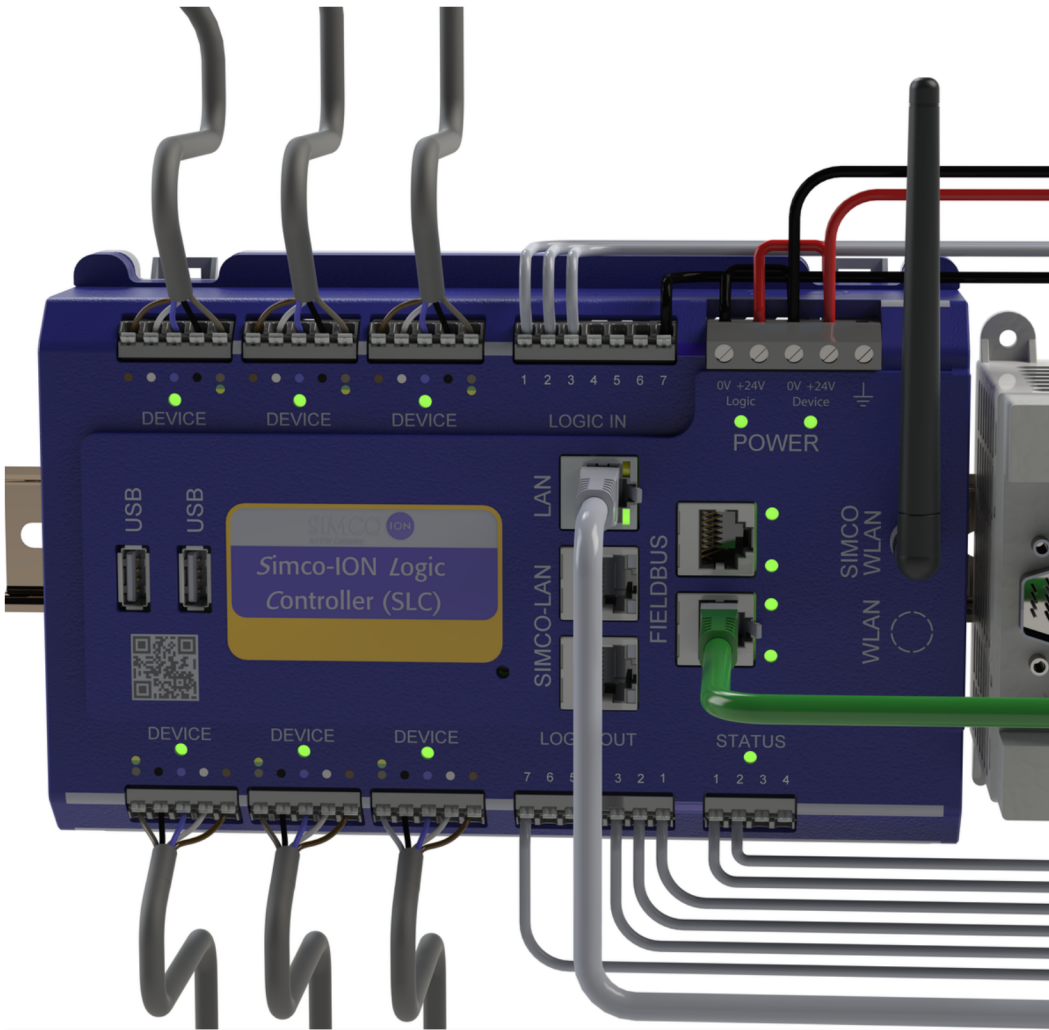

The Smart SLC in action. Connected to Fieldbus, LAN and linked to 6 devices.

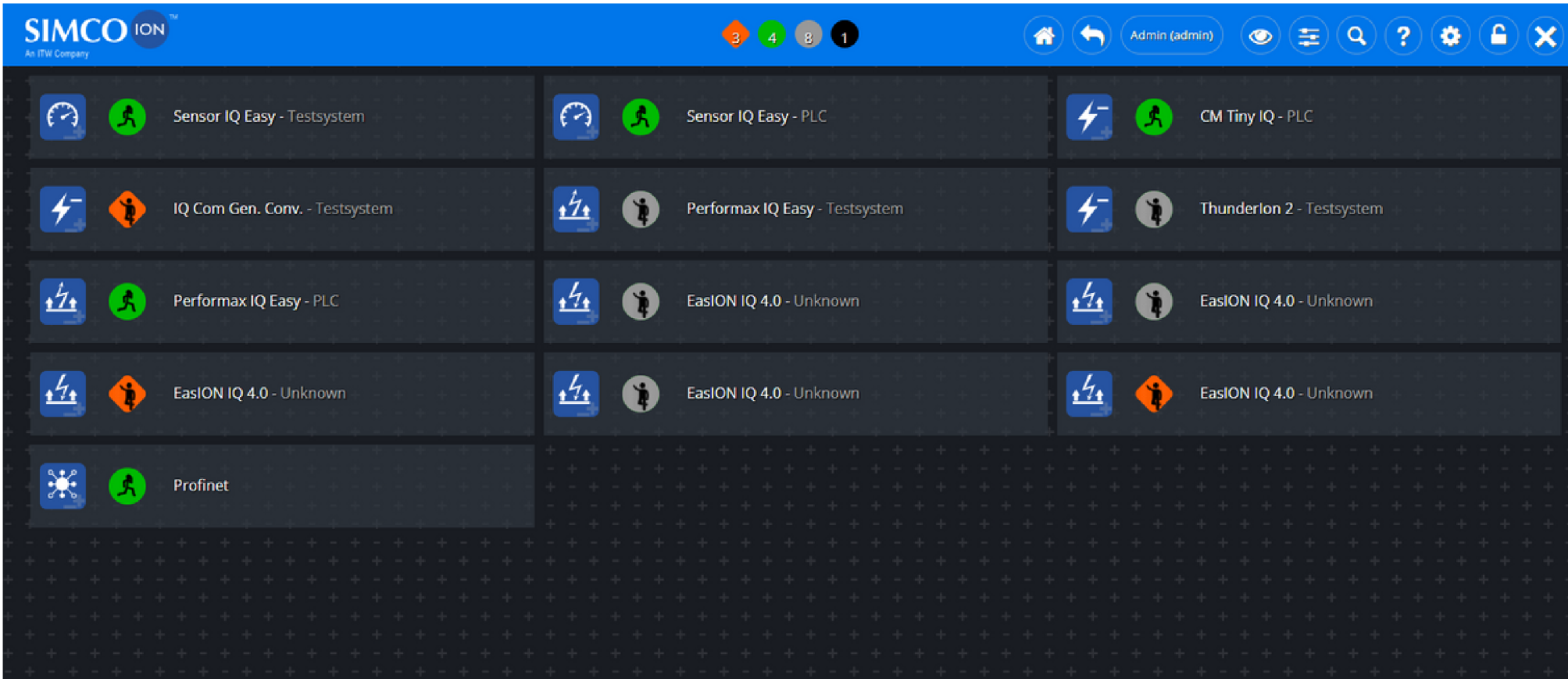

All new HMI interface. Either connect with your machine interface through Fieldbus, or manage the IQ system browser-based with a laptop, tablet or smartphone. You choose, the Smart SLC makes it possible.

Your electrostatic **competence center**

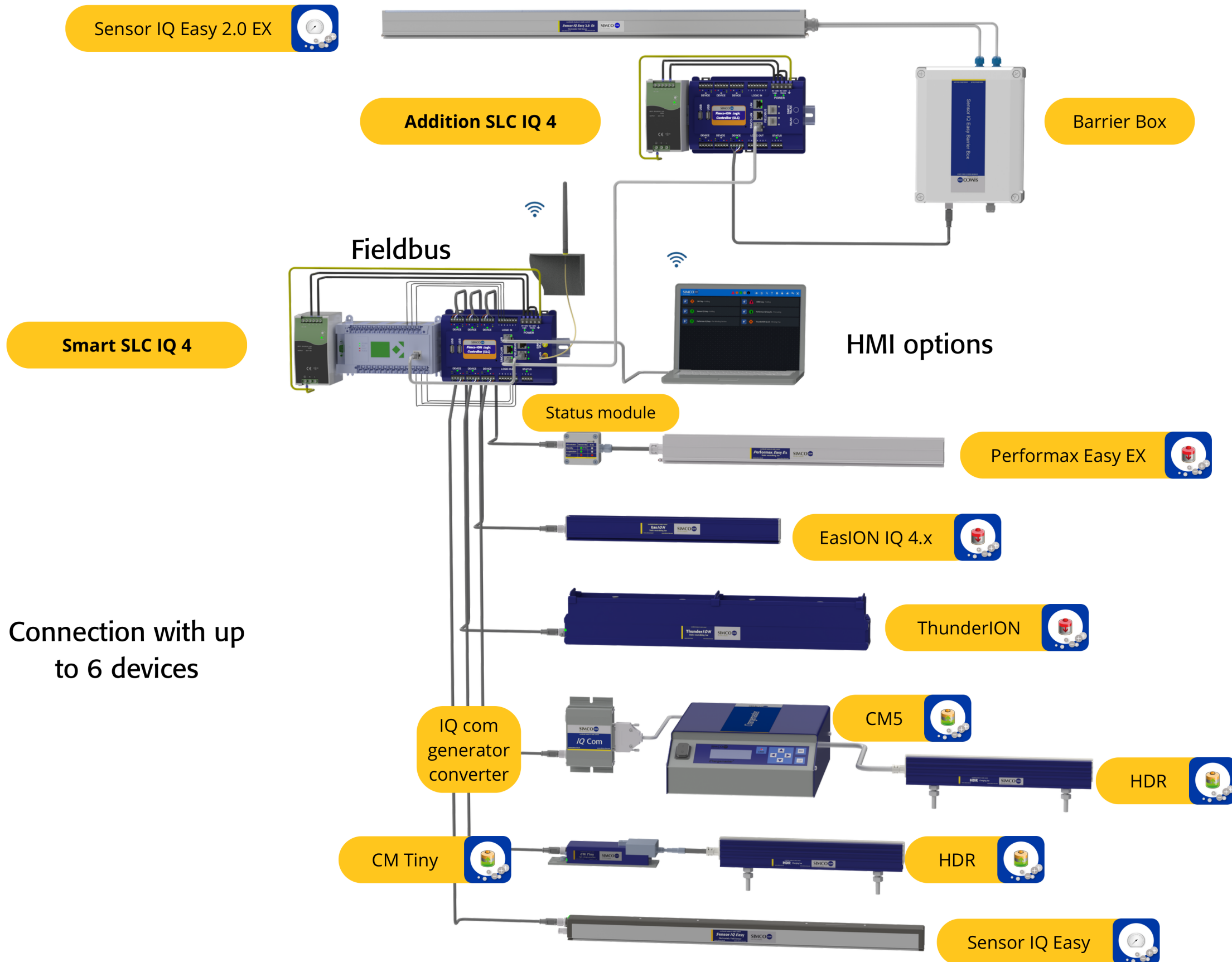



Connection with up to 6 devices

**When to choose for Simco-ION?**

If you want the highest standard of smart ionisation devices with indications about cleaning and efficiency, self-regulating efficiency through closed-loop feedback with quality control and data logging and excellent customer support. What else? Industry leading warranty, technical support on-site from our technical experts and our large Design and Engineering department with steady innovations to optimise your processes.

**Legend**



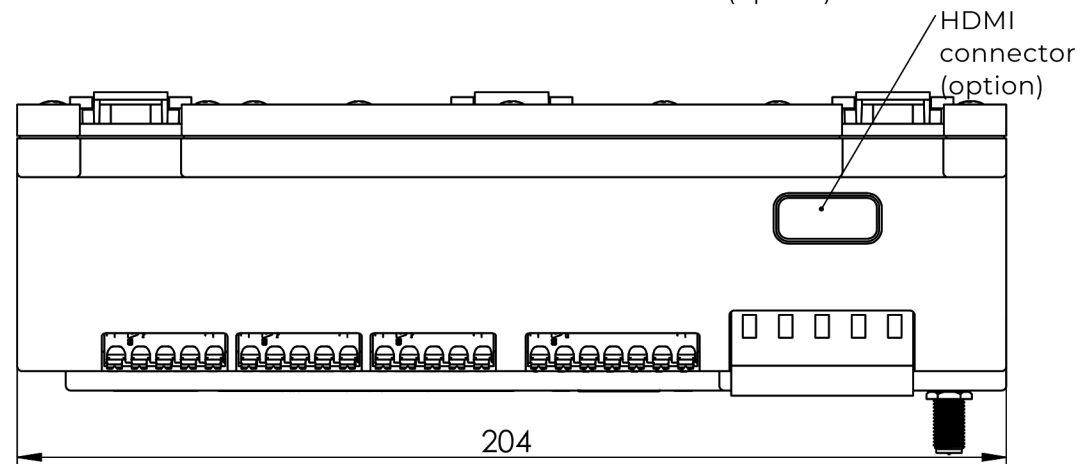
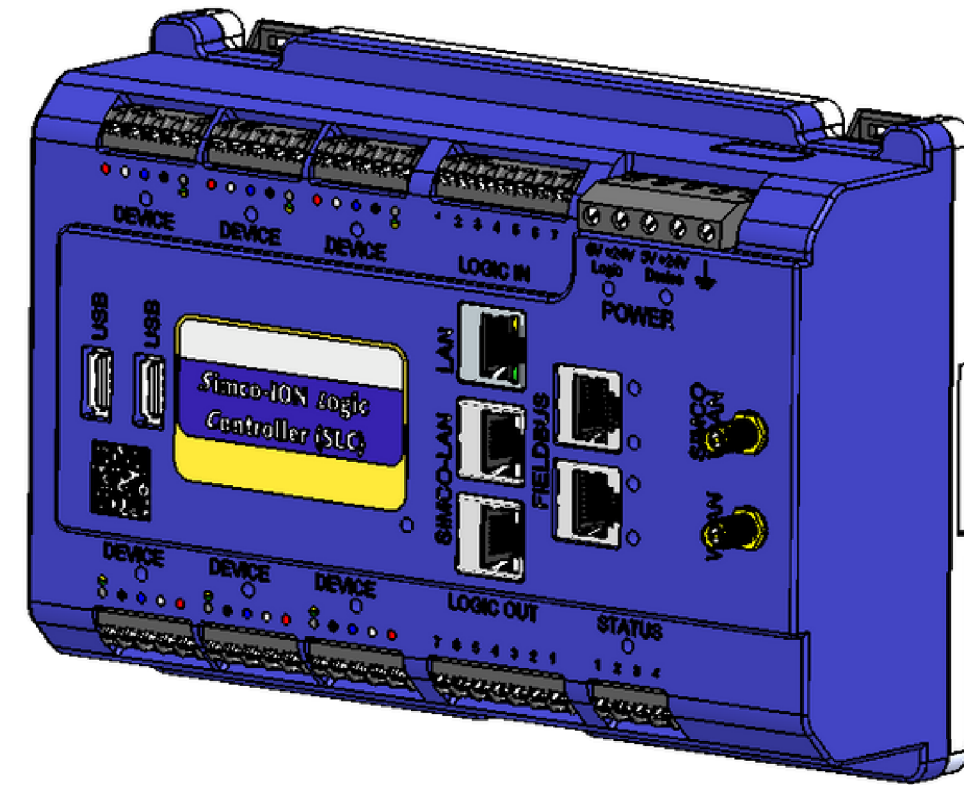
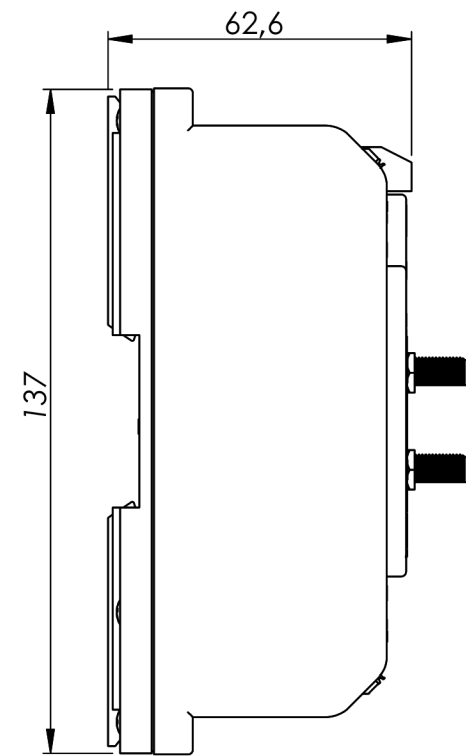
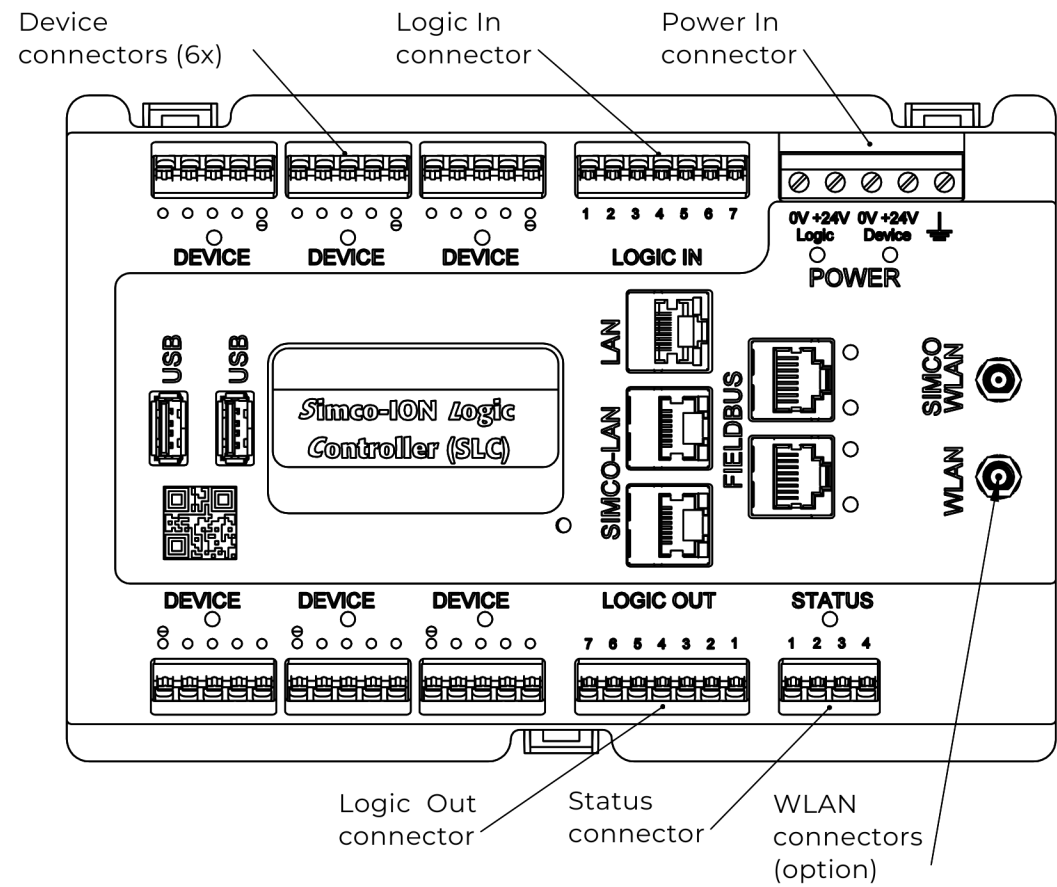

-  Charging products
-  Static elimination products
-  Electrostatic measuring products

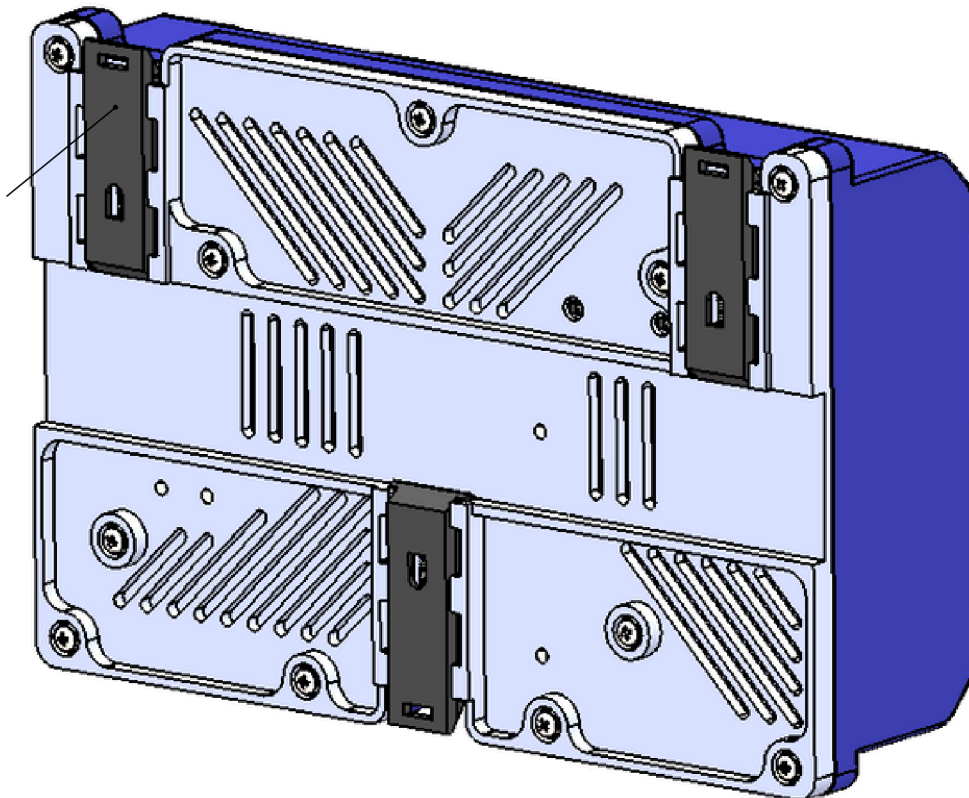

3 clips for DIN-rail mounting

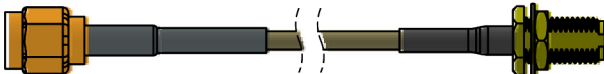

Included:

-  9380271030 WIFI Antenna
-  9380273546 Cable RP-SMA plug to BHD jack 0,45m
-  9380271020 U/UTP Cat6 cable 2m
-  9100302520 Cord end terminals 2,5 mm<sup>2</sup> 10 pcs
-  9100302520 Cord end terminals 0,34 mm<sup>2</sup> 100 pcs



Name: Smart SLC IQ 4				Drawn: RJ	Part no.: 103400xxxx
CAD GENERATED NOT AUTO UPDATED	Dimensions in mm	Date: 20-6-2023	A3	M:1:1,5	ECN-1034
Check: HS			Dwg. no.: 10340000/B		1/1