

AMS 358i

Optical laser measurement system – EtherNet/IP

Original operating instructions



© 2023

Leuze electronic GmbH + Co. KG

In der Braike 1

D-73277 Owen / Germany

Phone: +49 7021 573-0

Fax: +49 7021 573-199

<http://www.leuze.com>

info@leuze.de

The main menus

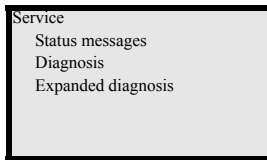
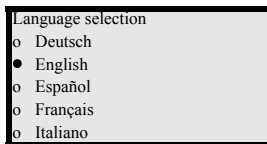
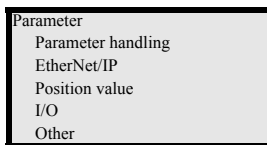
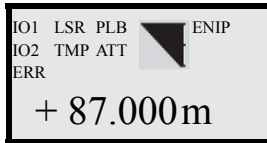
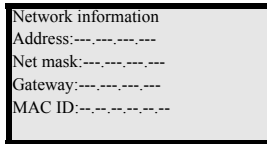
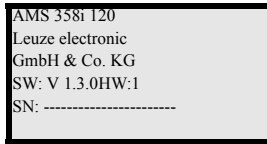

Device information - main menu

This menu item contains detailed information on

- Device type
- Manufacturer
- Software and hardware version
- Serial number

No entries can be made via the display.

Network information - main menu

Under this menu item, you will find detailed information on the network addresses.

No entries can be made via the display.

Status and measurement data - main menu

- Display of status, warning and error messages.
- Status overview of the switching inputs/ outputs
- Bar graph for the received signal level.
- Activated interface.
- Measurement value

No entries can be made via the display.
See "Indicators in the display" on page 43.

Parameter - main menu

- Configuration of the AMS.

See "Parameter menu" on page 49.

Language selection - main menu

- Selection of the display language.

See "Language selection menu" on page 53.

Service - main menu

- Display of status messages.
- Display of diagnostic data.

No entries can be made via the display.
See "Service menu" on page 53.

Device buttons:

- Navigate upward/sideways
- Navigate downward/sideways
- ESCAPE** leave
- ENTER** confirm

Input of values

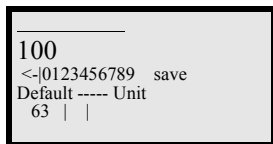

- + **Delete character**
- + + **Enter digit**
- save** + **Save input**

- 1 General information 5**
- 1.1 Explanation of symbols 5
- 1.2 Declaration of Conformity 5
- 1.3 Description of functions AMS 358/ 6

- 2 Safety 7**
- 2.1 Intended use 7
- 2.2 Foreseeable misuse 7
- 2.3 Competent persons 8
- 2.4 Exemption of liability 8
- 2.5 Laser safety notices 9

- 3 Fast commissioning / operating principle 12**
- 3.1 Mounting the AMS 358/ 12
- 3.1.1 Mounting the device 12
- 3.1.2 Mounting the reflector 12
- 3.2 Connecting the voltage supply 13
- 3.2.1 Connecting the EtherNet/IP network 13
- 3.3 Display 13
- 3.4 AMS 358/to EtherNet/IP 13

- 4 Technical data 17**
- 4.1 Technical data of laser measurement system 17
- 4.1.1 General specifications AMS 358/ 17
- 4.1.2 AMS 358/dimensioned drawing 19
- 4.1.3 Overview of AMS 358/types 20

- 5 Installation and mounting 21**
- 5.1 Storage, transportation 21
- 5.2 Mounting the AMS 358/ 22
- 5.2.1 Optional mounting bracket 24
- 5.2.2 Parallel mounting of the AMS 358/ 25
- 5.2.3 Parallel mounting of AMS 358/and DDLS optical data transmission 26
- 5.3 Mounting the AMS 358/with laser beam deflector unit 27
- 5.3.1 Mounting the laser beam deflector unit with integrated mounting bracket 27
- 5.3.2 Dimensioned drawing of US AMS 01 deflector unit 28
- 5.3.3 Mounting the US 1 OMS deflector unit without mounting bracket 29

6	Reflectors	30
6.1	General information	30
6.2	Description of the reflective tape	30
6.2.1	Technical data of self-adhesive tape	31
6.2.2	Technical data of reflective tape on carrier plate	31
6.2.3	Dimensioned drawing of reflective tape on carrier plate	32
6.2.4	Technical data of heated reflectors	33
6.2.5	Dimensioned drawing of heated reflectors	34
6.3	Selecting reflector size	35
6.4	Mounting the reflector	36
6.4.1	General information	36
6.4.2	Mounting the reflector	36
6.4.3	Table of reflector pitches	39
7	Electrical connection	40
7.1	Safety notices for the electrical connection	40
7.2	PWR – voltage supply / switching input/output	41
7.3	EtherNet/IP BUS IN	41
7.4	EtherNet/IP BUS OUT	42
7.5	Service	42
8	Display and control panel AMS 358/	43
8.1	Structure of the control panel	43
8.2	Status indicators and operation	43
8.2.1	Indicators in the display	43
8.2.2	LED status indicators	44
8.2.3	Control buttons	47
8.3	Menu description	48
8.3.1	The main menu	48
8.3.2	Parameter menu	49
8.3.3	Language selection menu	53
8.3.4	Service menu	53
8.4	Operation	54
9	EtherNet/IP interface	56
9.1	EtherNet/IP – General info	56
9.2	Topology	58

- 9.3 Addressing 58
- 9.3.1 Entering the network address via the display 59
- 9.4 EtherNet/IP device class 61
- 9.4.1 Communication / EDS file 61
- 9.5 EtherNet/IP - Electrical connection 62
- 9.6 EDS file - general info 63
- 9.7 Configuration steps for a Rockwell control without EDS support 64
- 9.7.1 Integrating the hardware into the PLC using the generic Ethernet module 64
- 9.8 Configuration steps for a Rockwell control with EDS support 65
- 9.8.1 Integrating the hardware into the PLC and installing the EDS file 65
- 9.9 Configuration examples 67
- 9.9.1 Example 1 - RSLogix 5000 up to software version V19.xx 67
- 9.9.2 Example 2 - RSLogix 5000 up to software version V19.xx 68
- 9.9.3 Example 3 - RSLogix 5000 for software versions V20.00 and higher 69
- 9.10 EDS file - detailed description 70
- 9.10.1 Class 4 Assembly 70
- 9.10.2 Class 1 Identity object 77
- 9.10.3 Class 35 Position sensor object 79
- 9.10.4 Class 100 Display configuration 86
- 9.10.5 Class 103 Switching inputs / outputs 88
- 9.10.6 Class 104 Error handling procedures 91
- 9.10.7 Class 105 Velocity monitoring 93

- 10 Diagnostics and troubleshooting 97**
- 10.1 Service and diagnosis in the display of the AMS 358/ 97
- 10.1.1 Status messages 97
- 10.1.2 Diagnosis 98
- 10.1.3 Expanded diagnosis 98
- 10.2 General causes of errors 99
- 10.2.1 Power LED 99
- 10.3 Interface errors 101
- 10.3.1 Net LED 101
- 10.4 Status indicators in the display of the AMS 358/ 101

- 11 Type overview and accessories 103**
- 11.1 Part number code 103
- 11.2 Overview of AMS 358/types (EtherNet/IP) 103
- 11.3 Overview of reflector types 104

11.4	Accessories	104
11.4.1	Accessories – Mounting bracket	104
11.4.2	Accessories – Deflector unit	104
11.4.3	Accessories – M12 connector	104
11.4.4	Accessories – Ready-made cables for voltage supply	105
11.4.5	Accessories - Ready-made cables for EtherNet/IP	106
12	Maintenance	108
12.1	General maintenance information	108
12.2	Repairs, servicing	108
12.3	Disassembling, packing, disposing	108

1 General information

1.1 Explanation of symbols

The symbols used in this technical description are explained below.



Attention!

This symbol precedes text messages which must strictly be observed. Failure to observe the provided instructions could lead to personal injury or damage to equipment.



Attention Laser!

This symbol warns of possible danger through hazardous laser radiation.



Note!

This symbol indicates text passages containing important information.

1.2 Declaration of Conformity

The AMS 358*i* absolute measuring optical laser measurement system was designed and manufactured in accordance with the applicable European directives and standards.

The AMS series is "UL LISTED" according to American and Canadian safety standards and fulfills the requirements of Underwriter Laboratories Inc. (UL).



Note!

The Declaration of Conformity for these devices can be requested from the manufacturer.

The manufacturer of the product, Leuze electronic GmbH & Co. KG in D-73277 Owen, possesses a certified quality assurance system in accordance with ISO 9001.



1.3 Description of functions AMS 358*i*

The AMS 358*i* optical laser measurement system calculates distances to fixed as well as moving system parts. The distance to be measured is calculated according to the principle of the propagation time of radiated light. Here, the light emitted by the laser diode is reflected by a reflector onto the receiving element of the laser measurement system. The AMS 358*i* uses the "propagation time" of the light to calculate the distance to the reflector. The high absolute measurement accuracy of the laser measurement system and the fast response time are designed for position control applications.

With its AMS 3xx*i* product series, Leuze makes available a wide range of internationally relevant interfaces. Note that each interface version listed below corresponds to a different AMS 3xx*i* model.



AMS 304*i*



AMS 348*i*



AMS 355*i*



AMS 358*i*



AMS 335*i*



AMS 338*i*



AMS 308*i*



AMS 384*i*



AMS 301*i*



AMS 300*i*

2 Safety

This sensor was developed, manufactured and tested in line with the applicable safety standards. It corresponds to the state of the art.

2.1 Intended use

The AMS is an absolute measuring optical laser measurement system which allows distance measurement of up to 300m against a reflector.

Areas of application

The AMS is designed for the following areas of application:

- Positioning of automated, moving plant components
- Travel and lifting axes of high-bay storage devices
- Repositioning units
- Gantry crane bridges and their trolleys
- Elevators
- Electroplating plants

	CAUTION
<p>Observe intended use!</p> <p>☞ <i>Only operate the device in accordance with its intended use. The protection of personnel and the device cannot be guaranteed if the device is operated in a manner not complying with its intended use.</i></p> <p><i>Leuze electronic GmbH + Co. KG is not liable for damages caused by improper use.</i></p> <p>☞ <i>Read the technical description before commissioning the device. Knowledge of this technical description is an element of proper use.</i></p>	

NOTE
<p>Comply with conditions and regulations!</p> <p>☞ <i>Observe the locally applicable legal regulations and the rules of the employer's liability insurance association.</i></p>



Attention

For UL applications, use is only permitted in Class 2 circuits in accordance with the NEC (National Electric Code).

2.2 Foreseeable misuse

Any use other than that defined under "Intended use" or which goes beyond that use is considered improper use.

In particular, use of the device is not permitted in the following cases:

- in rooms with explosive atmospheres
- as stand-alone safety component in accordance with the machinery directive ¹⁾
- for medical purposes

NOTE**Do not modify or otherwise interfere with the device!**

↪ *Do not carry out modifications or otherwise interfere with the device.*

The device must not be tampered with and must not be changed in any way.

The device must not be opened. There are no user-serviceable parts inside.

Repairs must only be performed by Leuze electronic GmbH + Co. KG.

2.3 Competent persons

Connection, mounting, commissioning and adjustment of the device must only be carried out by competent persons.

Prerequisites for competent persons:

- They have a suitable technical education.
- They are familiar with the rules and regulations for occupational safety and safety at work.
- They are familiar with the technical description of the device.
- They have been instructed by the responsible person on the mounting and operation of the device.

Certified electricians

Electrical work must be carried out by a certified electrician.

Due to their technical training, knowledge and experience as well as their familiarity with relevant standards and regulations, certified electricians are able to perform work on electrical systems and independently detect possible dangers.

In Germany, certified electricians must fulfill the requirements of accident-prevention regulations DGUV (German Social Accident Insurance) provision 3 (e.g. electrician foreman). In other countries, there are respective regulations that must be observed.

2.4 Exemption of liability

Leuze electronic GmbH + Co. KG is not liable in the following cases:

- The device is not being used properly.
- Reasonably foreseeable misuse is not taken into account.
- Mounting and electrical connection are not properly performed.
- Changes (e.g., constructional) are made to the device.

¹⁾ Use as safety-related component within the safety function is possible, if the component combination is designed correspondingly by the machine manufacturer.

2.5 Laser safety notices



ATTENTION! LASER RADIATION – CLASS 2 LASER PRODUCT

Do not stare into beam!

The device satisfies the requirements of IEC 60825-1:2014 / EN 60825-1:2014+A11:2021 safety regulations for a product of **laser class 2** and complies with 21 CFR 1040.10 except for conformance with IEC 60825-1 Ed. 3., as described in Laser Notice No. 56, dated May 8, 2019.

- ⚠ *Never look directly into the laser beam or in the direction of reflected laser beams!*
If you look into the beam path over a longer time period, there is a risk of injury to the retina.
- ⚠ *Do not point the laser beam of the device at persons!*
- ⚠ *Interrupt the laser beam using a non-transparent, non-reflective object if the laser beam is accidentally directed towards a person.*
- ⚠ *When mounting and aligning the device, avoid reflections of the laser beam off reflective surfaces!*
- ⚠ *CAUTION! The use of operating and adjustment devices other than those specified here or the carrying out of differing procedures may lead to dangerous exposure to radiation.*
- ⚠ *Observe the applicable statutory and local laser protection regulations.*
- ⚠ *The device must not be tampered with and must not be changed in any way.*
There are no user-serviceable parts inside the device.
Repairs must only be performed by Leuze electronic GmbH + Co. KG.

NOTE

Affix laser information and warning signs!

Laser information and warning signs are attached to the device (see figure 2.1). Also included with the device are self-adhesive laser warning and laser information signs (stick-on labels) in multiple languages (see figure 2.2).

- ⚠ *Affix the laser information sheet to the device in the language appropriate for the place of use.*
When using the device in the U.S.A., use the stick-on label with the "Complies with 21 CFR 1040.10" notice.
- ⚠ *Affix the laser information and warning signs near the device if no signs are attached to the device (e.g. because the device is too small) or if the attached laser information and warning signs are concealed due to the installation position.*
Affix the laser information and warning signs so that they can be read without the reader being exposed to the laser radiation of the device or other optical radiation.

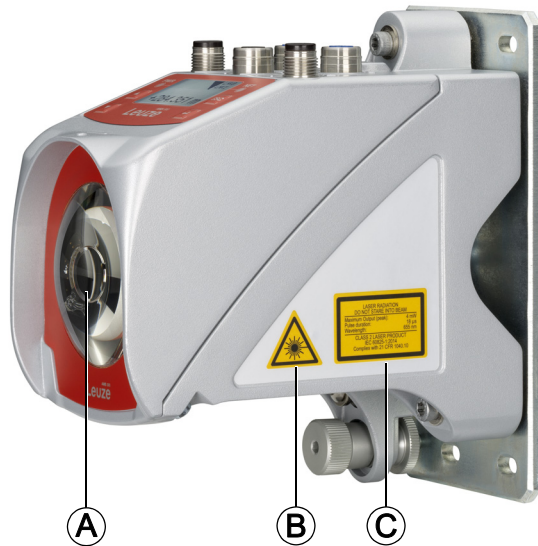

- A** Laser aperture
- B** Laser warning sign
- C** Laser information sign with laser parameters

Figure 2.1: Laser apertures, laser warning signs



Figure 2.2: Laser warning and information signs – supplied stick-on labels

3 Fast commissioning / operating principle



Note!

Below you will find a **short description for the initial commissioning** of the AMS 358*i*. Detailed explanations for the listed points can be found throughout the handbook.

3.1 Mounting the AMS 358*i*

The AMS 358*i* and the corresponding reflector are mounted on two mutually opposing, plane-parallel, flat walls.



Figure 3.1: Schematic illustration of mounting



Attention!

For error-free position measurement, there must be an unobstructed line-of-sight between the AMS 358*i* and the reflector.

3.1.1 Mounting the device

The laser is mounted using 4 screws (M5).

Alignment is performed using 2 adjustment screws. Adjust so that the laser light spot is positioned at the center of the reflector. The alignment is secured with the knurled nut and locked with the M5 nut.

Detailed information can be found in Chapter 5.2 and Chapter 5.3.

3.1.2 Mounting the reflector

The reflector is available both as self-adhesive film or premounted on a metal plate. The reflector on the metal plate is mounted using 4 screws (M5). The reflector is angled using the spacer sleeves included. Incline the reflector by approx. 1°.

The self-adhesive film is attached in the same way. In this case, however, the metal plate must be provided at the installation site.

Detailed information can be found in Chapter 6.4.

3.2 Connecting the voltage supply

The laser measurement system is connected using M12 connectors. The voltage supply is connected via the **PWR** M12 connection.

Detailed information can be found in Chapter 7.

3.2.1 Connecting the EtherNet/IP network

EtherNet/IP is connected via D-coded M12 connectors for **BUS IN** and **BUS OUT**. BUS IN and BUS OUT are coupled via an internal switch.

Detailed information can be found in Chapter 7.

3.3 Display

Once the laser measurement system is supplied with voltage, the device status as well as the measured position values can be read on the display. The display automatically switches to the display of the measurement values.

Use the up/down buttons (▲ ▼) to the left of the display to read and change a wide range of data and parameters.

Depending on the connected interface, the network address must be configured via the display.

Detailed information can be found in Chapter 8.

3.4 AMS 358/i to EtherNet/IP



Note!

Before commissioning, the EDS file of the AMS 358/i should be installed in the corresponding control.

Commissioning on the EtherNet/IP is performed according to the following scheme:

1. Activate parameter enable
2. Address assignment (manual or automatic via DHCP or BootP)
3. Deactivate parameter enable
4. Configuration of the participant
5. Transferring the data to the control
6. Configuration of the config assembly; when doing so, it is essential to refer to Chapter 9.6
7. Using explicit messaging services

Activate parameter enable

To perform address assignment described below, parameter enable must first be activated.

☞ *To do so, select the menu item ON in the menu Parameter -> Parameter handling -> Parameter enable.*

**Note!**

The display is inverted when parameter enable is active.

Manual address assignment of network addresses of AMS 358*i*

Under the menu item EtherNet/IP in the display, you will find input masks for

- IP address
- network mask (subnet)
- gateway address (if a gateway is present)

☞ *Enter the corresponding addresses.*

Automatic address assignment via DHCP

Under the menu item EtherNet/IP, you will find the input mask for activating and deactivating the DHCP functionality. DHCP address assignment is set to "ON" by default.

☞ *To deactivate DHCP, select OFF.*

If the DHCP server supplies the corresponding addresses, the address fields for IP address, network mask and gateway address are preset by the DHCP server.

Automatic address assignment via BootP

Under the menu item EtherNet/IP, you will find the input mask for activating and deactivating the BootP functionality. By default, the BootP address assignment is set to "OFF".

☞ *To activate BootP, select ON.*

If the BootP server supplies the corresponding addresses, the address fields for IP address, network mask and gateway address are preset by the BootP server.

**Note!**

The data can be called up via the display in the main menu under Network information.

Deactivate parameter enable

☞ *Deactivate parameter enable by selecting the menu item OFF in the menu Parameter -> Parameter handling -> Parameter enable.*

Configuring the participant (up to software version 20.00).

In the RSLogix 5000 configuration tool for EtherNet/IP, a so-called "generic Ethernet module" is created under the "Communication" path for the AMS 358*i*.

The input mask for the generic module describes:

- The name of the participant (can be selected freely; e.g. AMS358i_1).
- The format of the I/O data (data - DINT = 32bit).
- The IP address of the participant.
- The address and length of the input assembly (instance 1; 1 x 32bit for the default input assembly of the measurement values).
- The address and length of the output assembly (instance 120; 2 x 32bit for the default output assembly).
- Optional: The address and length of the configuration assembly (instance 190; 102 x 8bits).

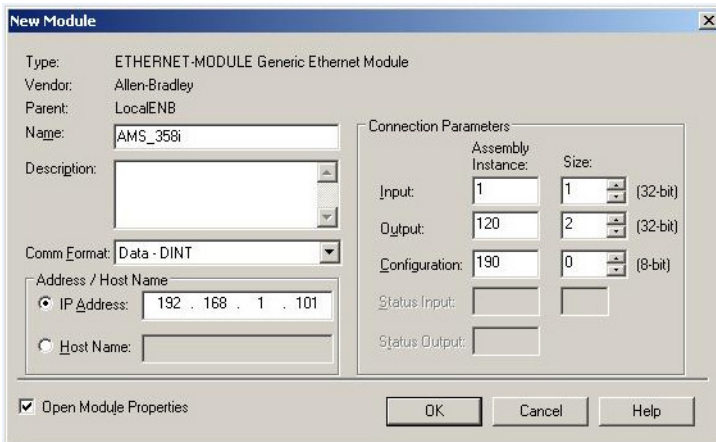

Figure 3.2: Input mask generic module



Attention!

If the configuration assembly is addressed with instance 190 and length 102 in the input mask for the generic module, all AMS 358i parameters with the value 0 are occupied in the first moment. All default parameters of the AMS must be manually entered in the configuration assembly. Changing the individual default values is possible at any time.

For the exact description of the assemblies for input/output and configuration, please refer to Chapter 9.10.

The query cycle of the input and output assemblies is subsequently defined in the "Module properties -> Connection" path in the "Request packet interval (RPI)" input field.

The participant is thereby defined in off-line mode; the data must subsequently be transferred to the control.

Transferring the data to the control (RSLogix 5000 specific)

- ↳ *Activate the online mode.*
- ↳ *Select the Ethernet communication port.*
- ↳ *Select the processor onto which the project is to be transferred..*
- ↳ *Set the control to "PROG".*
- ↳ *Start the download.*
- ↳ *Set the control to "RUN".*

Configuring the config assembly

The AMS 358*i* makes available a configuration assembly that allows the entire parameter set of the AMS 358*i* to be saved in the control and, if necessary, to be called up.

The config assembly must include all parameters that affect the AMS 358*i*. The config assembly is automatically written to the connected participants in cycles that the control manufacturer defines.

The config assembly is implemented in class 4, under instance 190. By default, all parameters are preset to the value 0 (zero).

**Attention!**

*If the config assembly is not adapted, the AMS 358*i* displays a corresponding behavior acc. to the parameters preset with 0.*

- ↳ *Switch the control to offline mode.*
- ↳ *Double-click Controller tags to edit the configuration assembly.*

The configuration assembly can be recognized by the index "C" appended to the device name. Parameters are entered as described under Chapter 9.10.1.6.

**Attention!**

Activation of the config assembly as described above necessitates value entry in the corresponding parameter memory locations. When using the configuration assembly, the default parameters must also be entered in the corresponding memory locations (see also Chapter 9.10.1.6).

*After all of the parameters relevant to the AMS 358*i* are entered, the control is switched to "online" and the project is downloaded again.*

Using explicit messaging services

Explicit messaging services (e.g., "get attributes ...", "set attribute ...", and others) can be used to acyclically access all data of the AMS 358*i*

**Attention!**

If parameters are changed via explicit messaging services while simultaneously activating a configuration assembly, the changed parameters must subsequently be entered in the configuration assembly.

4 Technical data

4.1 Technical data of laser measurement system

4.1.1 General specifications AMS 358/

Measurement data	AMS 358/40 (H)	AMS 358/120 (H)	AMS 358/200 (H)	AMS 358/300 (H)
Measurement range	0.2 ... 40m	0.2 ... 120m	0.2 ... 200m	0.2 ... 300m
Accuracy	± 2mm	± 2mm	± 3mm	± 5mm
Reproducibility ¹⁾	0.3mm	0.5mm	0.7mm	1.0mm
Light spot diameter	≤ 40mm	≤ 100mm	≤ 150mm	≤ 225mm
Output time			1.7 ms	
Response time			14ms	
Basis for contouring error calculation			7 ms	
Resolution	Adjustable; see chapters on individual interfaces			
Temperature drift			≤ 0.1mm/K	
Ambient temperature sensitivity			1 ppm/K	
Air pressure sensitivity			0.3ppm/hPa	
Traverse rate			≤ 10m/s	
Electrical data				
Supply voltage V_{in} ²⁾			18 ... 30VDC	
Current consumption			Without device heating: ≤ 250mA / 24VDC With device heating: ≤ 500mA / 24VDC	
Optical data				
Transmitter			Laser diode, red light	
Laser class	2 in acc. with IEC 60825-1:2014 / EN 60825-1:2014+A11:2021			
Wavelength			655nm	
Impulse duration			≤ 0.8µs	
Max. output power (peak)			≤ 4mW	
Interfaces				
EtherNet/IP			10/100Mbit/s	
Vendor ID			524 _{Dez} / 20C _H	
Device type			34 _{Dez} / 22 _H (encoder)	
Position sensor type			8 _{Dez} / 8 _H (absolute encoder)	
Controls and indicators				
Keyboard			4 keys	
Display			Monochromatic graphical display, 128 x 64 pixels	
LED			4 LEDs, 2 of which are used to indicate the state of the EtherNet/IP connection	

Inputs/outputs

Quantity	2, programmable
Input	Protected against polarity reversal
Output	Max. 60 mA, short-circuit-proof

Mechanical data

Housing	Diecast zinc/aluminum
Optics	Glass
Weight	Approx. 2.45 kg
Degree of protection	IP 65 acc. to EN 60529 ³⁾

Environmental conditions

Operating temperature	
without device heating	-5 °C ... +50 °C
with device heating	-30 °C ... +50 °C ⁴⁾
Storage temperature	-30 °C ... +70 °C
Air humidity	Max. 90% rel. humidity, non-condensing
MTTF	31 years (at 25 °C) ⁵⁾

Mechanical/electrical loading capacity

Vibration	Acc. to EN 60068-2-6
Noise	Acc. to EN 60060-2-64
Shock	Acc. to EN 60068-2-27
EMC	Acc. to EN 61000-6-2 and EN 61000-6-4 ⁶⁾

- 1) Statistical error: 1 sigma; minimum switch-on time: 2 min.
- 2) For UL applications: only for use in "Class 2" circuits according to NEC.
- 3) With screwed-on M12 connectors or mounted caps.
- 4) With devices with heating, the switch on/off area of the internal heating can be extended to prevent condensation from forming. Total prevention of condensation cannot be guaranteed due to the limited heating capacity of the AMS 358/.
- 5) We reserve the right to make changes. (Value is updated at regular intervals.)
- 6) This is a Class A product. In a domestic environment this product may cause radio interference, in which case the operator may be required to take adequate measures.



The AMS 358/ is designed in accordance with protection class III for supply with PELV (protective extra-low voltage).

4.1.2 AMS 358/i dimensioned drawing

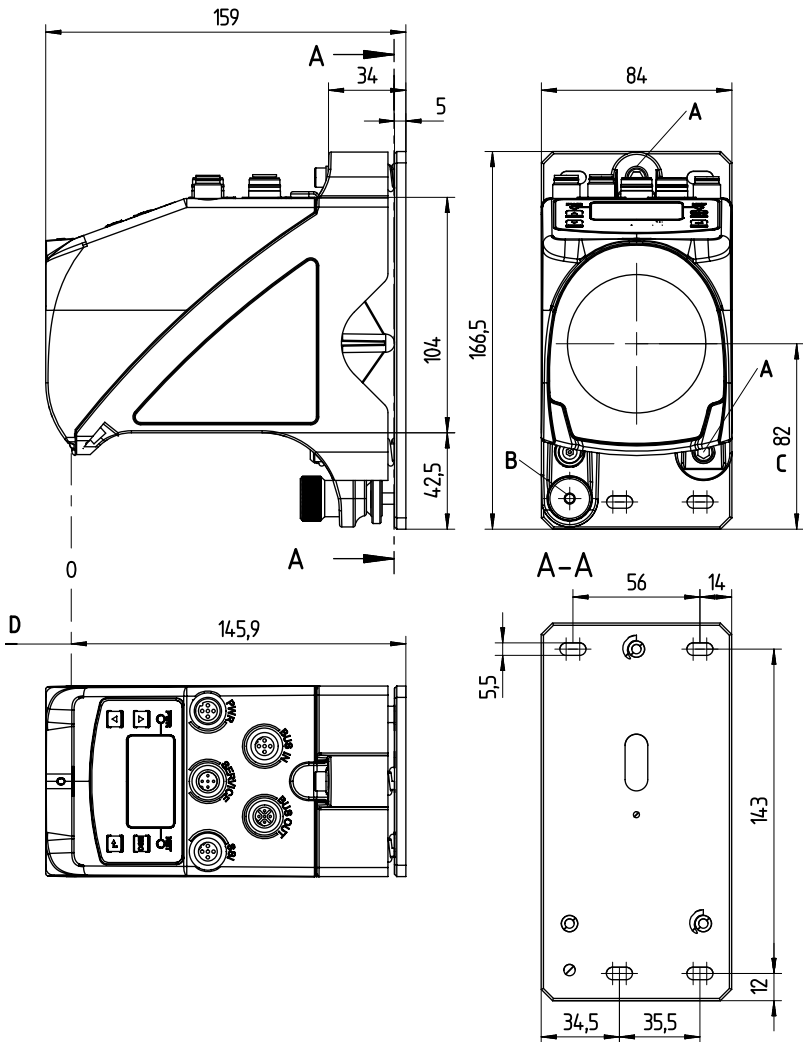

- A** M 5 screw for alignment
- B** Knurled nut with WAF4 hexagon socket and M5 nut for securing
- C** Optical axis
- D** Zero point of the distance to be measured

Figure 4.1: AMS 358/i dimensioned drawing

4.1.3 Overview of AMS 358*i* types

AMS 358*i* (EtherNet/IP)

Type designation	Description	Part no.
AMS 358 <i>i</i> /40	40m operating range, EtherNet/IP interface	50113725
AMS 358 <i>i</i> /120	120m operating range, EtherNet/IP interface	50113726
AMS 358 <i>i</i> /200	200m operating range, EtherNet/IP interface	50113727
AMS 358 <i>i</i> /300	300m operating range, EtherNet/IP interface	50113728
AMS 358 <i>i</i> /40 H	40m operating range, EtherNet/IP interface, integrated heating	50113729
AMS 358 <i>i</i> /120 H	120m operating range, EtherNet/IP interface, integrated heating	50113730
AMS 358 <i>i</i> /200 H	200m operating range, EtherNet/IP interface, integrated heating	50113731
AMS 358 <i>i</i> /300 H	300m operating range, EtherNet/IP interface, integrated heating	50113732

Table 4.1: Overview of AMS 358*i* types

5 Installation and mounting

5.1 Storage, transportation



Attention!

Package the device for transport and storage in such a way that is protected against shock and humidity. Optimum protection is achieved when using the original packaging. Ensure compliance with the approved environmental conditions listed in the specifications.

Unpacking

- ✦ Check the packaging content for any damage. If damage is found, notify the post office or shipping agent as well as the supplier.
- ✦ Check the delivery contents using your order and the delivery papers:
 - Delivered quantity
 - Device type and model as indicated on the name plate
 - Brief manual

The name plate provides information as to what AMS 358*i* type your device is. For specific information, please refer to Chapter 11.2.

Name plates



Figure 5.1: Device name plate using the AMS 358*i* as an example



Note!

Please note that the shown name plate is for illustration purposes only; the contents do not correspond to the original.

- ✦ Save the original packaging for later storage or shipping.

If you have any questions concerning your shipment, please contact your supplier or your local Leuze sales office.

🗑️ *Observe the applicable local regulations when disposing of the packaging materials.*

5.2 Mounting the AMS 358/

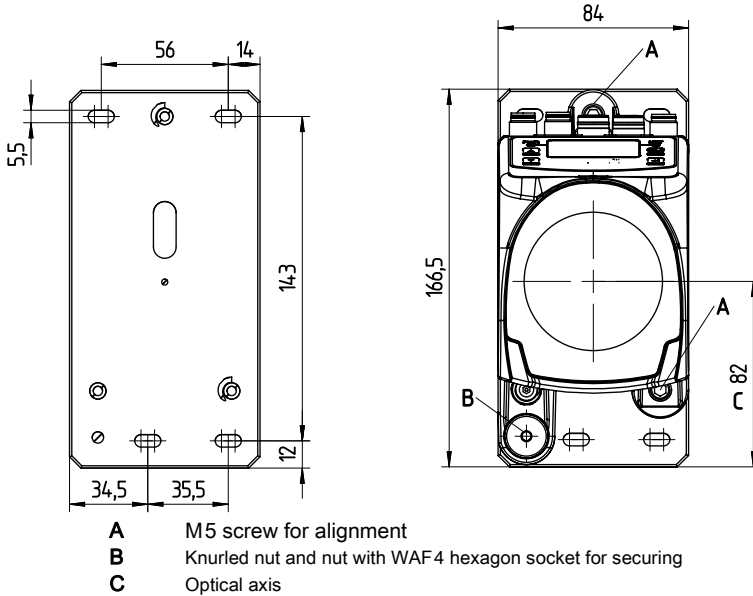

Figure 5.2: Mounting the device

The AMS 358/ and the corresponding reflector are mounted on two mutually opposing, plane-parallel, flat walls or system parts. For error-free position measurement, there must be an unobstructed line-of-sight between the AMS 358/ and the reflector.

Use M5 screws to fasten the laser measurement system. Secure the screws with a lock washer to protect against loosening caused by vibrations.

Aligning the laser light spot with the center of the reflector

The laser light spot has to be aligned so that it always hits the center of the opposing reflector, both at close range as well as at the maximum measurement distance. **To align, use the two M5 Allen screws ("A" in Figure 5.2).** When aligning, please ensure that the knurled nut and the lock nut ("B" in Figure 5.2) are opened wide.



Attention!

To prevent the laser measurement system from moving out of alignment during continuous operation, subsequently hand-tighten the knurled nut and counterlock with the nut with WAF4 hexagon socket ("B" in Figure 5.2). Knurled nut and nut must not be tightened until alignment has been completed.



Attention!

The device must not be opened. Failure to comply will render the guarantee void. Warranted features cannot be guaranteed after the device has been opened.

5.2.1 Optional mounting bracket

A mounting bracket for mounting the AMS 358/i on a flat, horizontal surface is available as an optional accessory.

Type designation: MW OMS/AMS 01

Part no.: 50107255

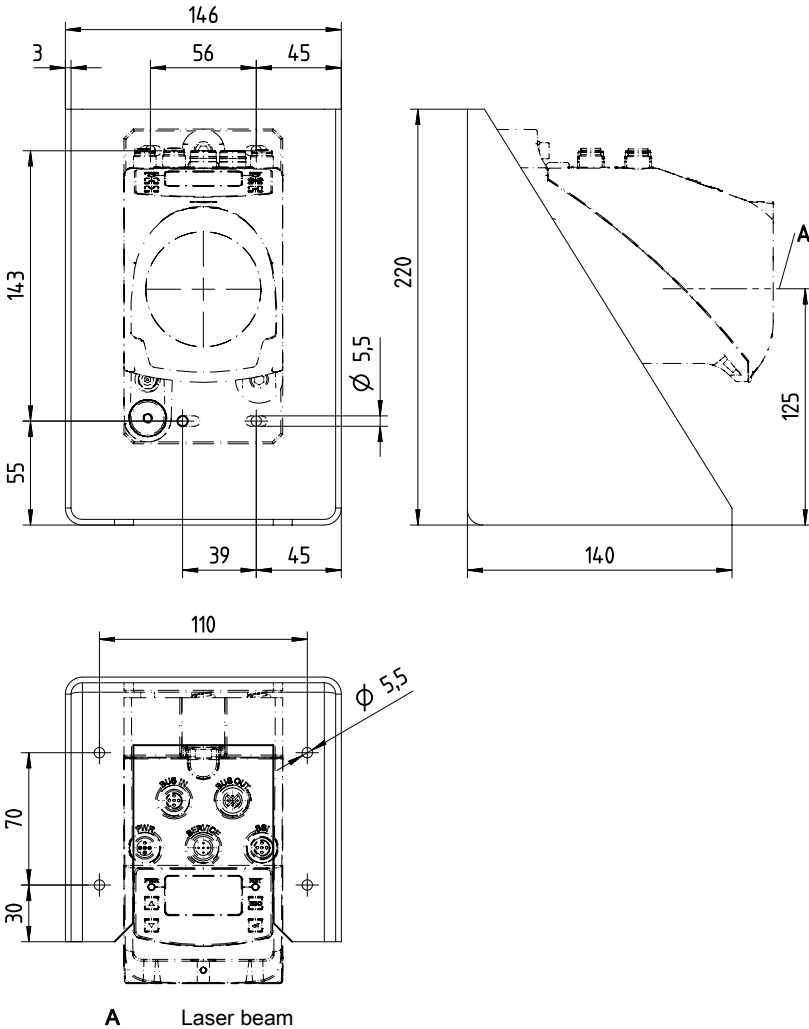

Figure 5.3: Optional mounting bracket

5.2.2 Parallel mounting of the AMS 358/

Definition of the term "parallel spacing"

As shown in Figure 5.4, dimension X describes the "parallel spacing" of the inner edges of the two laser light spots on the reflector.

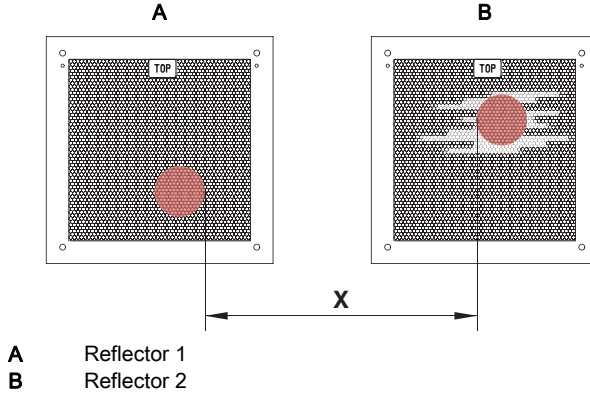

Figure 5.4: Minimum parallel spacing X between adjacent AMS 358/

The diameter of the light spot increases with distance.

	AMS 358/40 (H)	AMS 358/120 (H)	AMS 358/200 (H)	AMS 358/300 (H)
Max. measurement distance	40m	120m	200m	300m
Light spot diameter	≤ 40mm	≤ 100mm	≤ 150mm	≤ 225mm

Thus, the center-to-center spacing of the two AMS 358/ devices with respect to one another can be calculated as a function of the maximum measurement distance.

To define the minimum parallel spacing between two AMS 358/, it is necessary to distinguish between three different arrangements of AMS 358/ and reflectors.

The AMS 358/ are mounted stationary and in parallel on one plane.

Both reflectors move independently of one another at different distances to the AMS 358/.

Minimum parallel spacing X of the two laser light spots:

$$X = 100\text{mm} + (\text{max. measurement distance in mm} \times 0.01)$$

The AMS 358/ are mounted stationary and in parallel on one plane.

Both reflectors move in parallel at the same distance to the AMS 358/.

Measurement distance up to 120m: minimum parallel spacing X ≥ 600mm

Measurement distance up to 200m: minimum parallel spacing X ≥ 750mm

Measurement distance up to 300m: minimum parallel spacing X ≥ 750mm

The reflectors are mounted stationary and in parallel on one plane.

Both AMS 358*i* move independently of one another at different or the same distances to the reflectors.

Measurement distance **up to 120m**: minimum parallel spacing $X \geq 600\text{mm}$

Measurement distance **up to 200m**: minimum parallel spacing $X \geq 750\text{mm}$

Measurement distance **up to 300m**: minimum parallel spacing $X \geq 750\text{mm}$



Note!

*Please note that when the AMS 358*i* are mounted in a mobile manner, travel tolerances could cause the two laser light spots to move towards each other.*

*Take the travel tolerances of the vehicle into account when defining the parallel spacing of adjacent AMS 358*i*.*

5.2.3 Parallel mounting of AMS 358*i* and DDLS optical data transmission

The optical data transceivers of the DDLS series and the AMS 358*i* do not interfere with one another. Depending on the size of the used reflector, the DDLS can be mounted with a minimum parallel spacing of 100mm to the AMS 358*i*. The parallel spacing is independent of the distance.

5.3 Mounting the AMS 358*i* with laser beam deflector unit

General information

The two available deflector units are used for the 90° deflection of the laser beam, see "Accessories – Deflector unit" on page 104.



Attention!

The deflector units are designed for a maximum range of 40m. Longer distances on request.

5.3.1 Mounting the laser beam deflector unit with integrated mounting bracket

The AMS 358*i* is screwed onto the mechanism of the US AMS 01 deflector unit. The mirror can be mounted for three deflection directions:

1. Upward beam deflection
2. Beam deflection to the left
3. Beam deflection to the right

The deflector unit is mounted on plane-parallel, flat walls or system parts. For error-free position measurement, there must be an unobstructed line-of-sight between the AMS 358*i*... and the deflection mirror as well as between the mirror and the reflector.

Use the M5 screws to mount the deflector unit. Secure the screws with a lock washer to protect against loosening caused by vibrations.



Figure 5.5: Mounting variants of the US AMS 01 laser beam deflector unit

5.3.2 Dimensioned drawing of US AMS 01 deflector unit

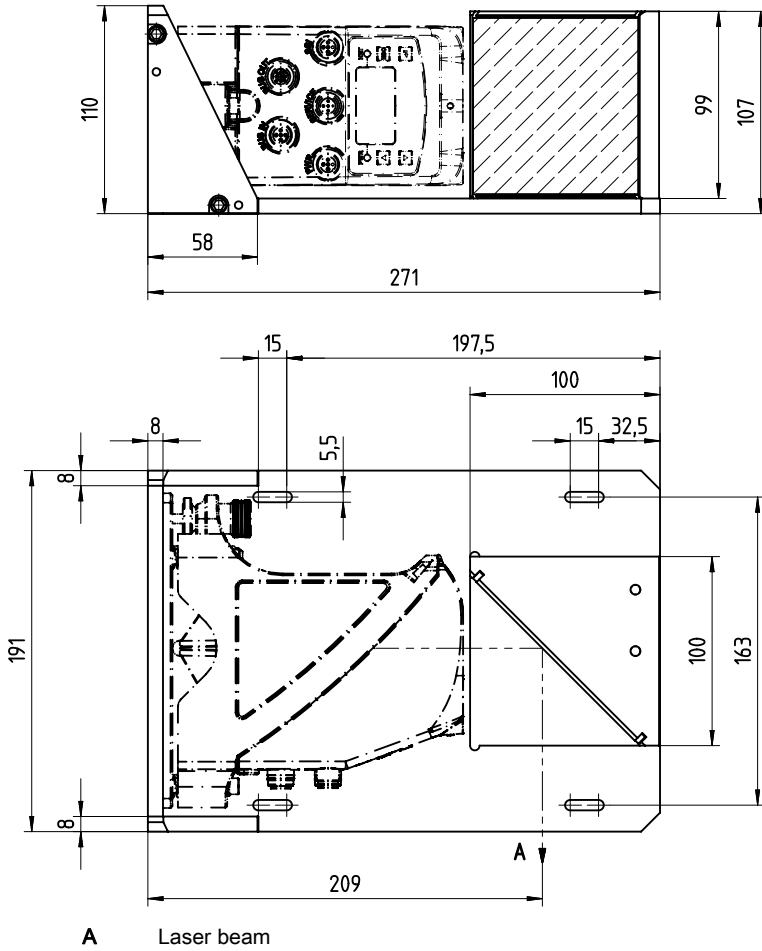

Figure 5.6: Dimensioned drawing of US AMS 01 deflector unit

5.3.3 Mounting the US 1 OMS deflector unit without mounting bracket

The US 1 OMS deflector unit and the AMS 358*i* are mounted separately.



Note!

When mounting, make certain that the laser light spot of the AMS 358*i* is aligned with the center of the deflection mirror.

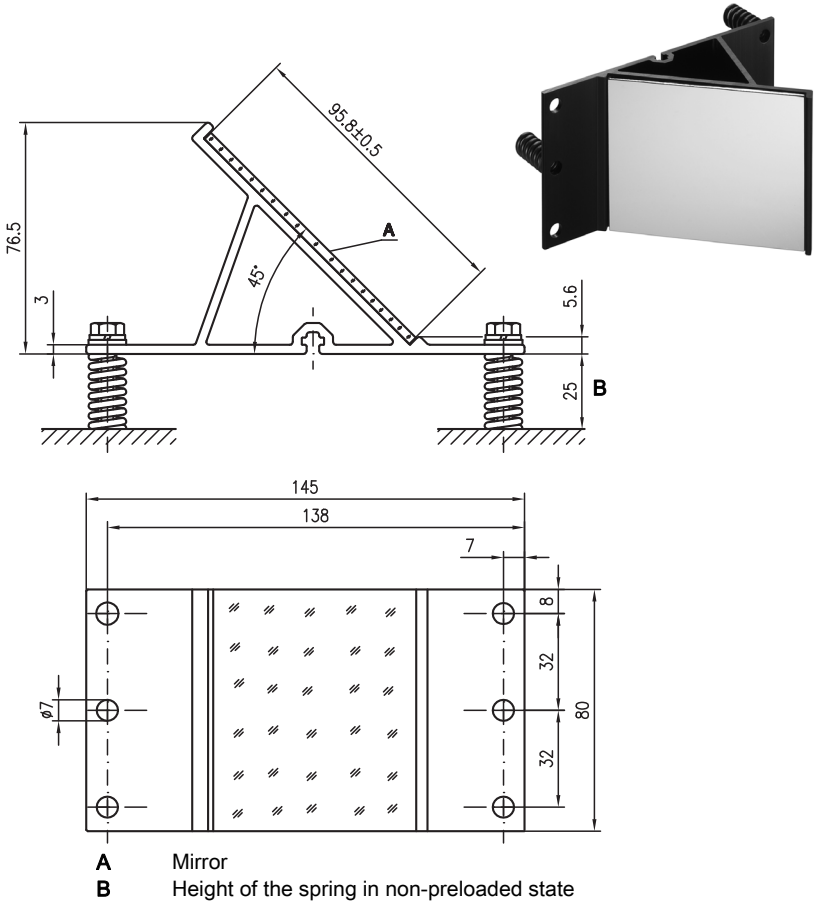

Figure 5.7: Photo and dimensioned drawing of the US 1 OMS deflector unit

The laser light spot is aligned with the reflector as described in Chapter 5.2.

6 Reflectors

6.1 General information

The AMS 358*i* measures distances against a reflective tape specified by Leuze. All technical data given for the AMS 358*i*, such as the operating range or accuracy, can only be achieved with the reflective tape specified by Leuze.

The reflective tapes are available as self-adhesive tapes or affixed to a carrier plate and with an integrated heater especially for use at low temperatures. Reflective tapes with heating have the designation "**Reflective tape ...x...-H**", where "**H**" is an abbreviation for the heating variant.

The reflective tapes/reflectors must be ordered separately. The choice of size is left to the user. In Chapter 6.3, recommendations on reflector size are given depending on the distance that is to be measured. In each case, the user must check whether the recommendation is suitable for the respective application.

6.2 Description of the reflective tape

The reflective tape consists of a white, microprism-based reflective material. The microprisms are protected by a hard, highly transparent protective layer.

Under certain circumstances, the protective layer can cause surface reflections. The surface reflections can be directed past the AMS 358*i* by positioning the reflective tape at a slight incline. The inclination of the reflective tape/reflectors is described in Chapter 6.4.2. The required pitch can be found in Table 6.1 "Reflector pitch resulting from spacer sleeves" on page 39.

The reflective tapes have a protective film that is easy to peel off. It must be removed from the reflector before the complete system is put into operation.

6.2.1 Technical data of self-adhesive tape

Type designation	Article				
	Reflective tape 200x200-S	Reflective tape 500x500-S	Reflective tape 914x914-S	REF 4-A- 150x150	REF 4-A- 300x300
Part no.	50104361	50104362	50108988	50141015	50141014
Film size	200 x 200mm	500 x 500mm	914x914mm	150 x 150 mm	300 x 300 mm
Recommended application temperature for adhesive tape	+5°C ... +25°C				
Temperature resistance, affixed	-40°C ... +80°C				
Bonding surface	The bonding surface must be clean, dry and free of grease.				
Cutting tape	Cut with a sharp tool, always on the side with the prism structure.				
Cleaning	Do not use any abrasive agents. A conventional household detergent can be used as a cleaning agent. Rinse with clear water and dry the surface.				
Film storage	Store in a cool and dry place.				

6.2.2 Technical data of reflective tape on carrier plate

The reflective tape is affixed to a carrier plate. Included with the carrier plate are spacers for positioning at an incline in order to avoid surface reflections (see chapter 6.4.2 "Mounting the reflector").

Type designation	Article		
	Reflective tape 200x200-M	Reflective tape 500x500-M	Reflective tape 914x914-M
Part no.	50104364	50104365	50104366
Film size	200 x 200mm	500 x 500mm	914x914mm
Outer dimensions of carrier plate	250 x 250mm	550 x 550mm	964 x 964mm
Weight	0.4kg	1.6kg	6kg
Cleaning	Do not use any abrasive agents. A conventional household detergent can be used as a cleaning agent. Rinse with clear water and dry the surface.		
Reflector storage	Store in a cool and dry place.		

6.2.3 Dimensioned drawing of reflective tape on carrier plate

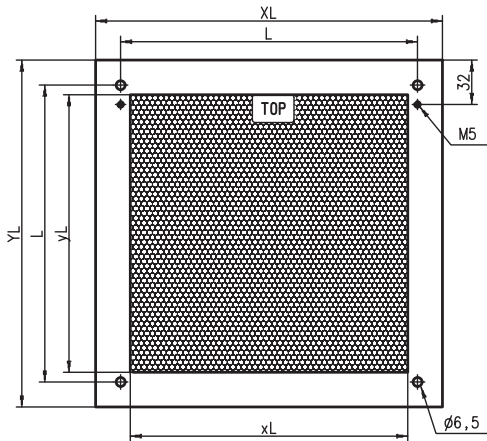

 Always align the **TOP** marking with the AMS connections! (Chapter 6.4.2)

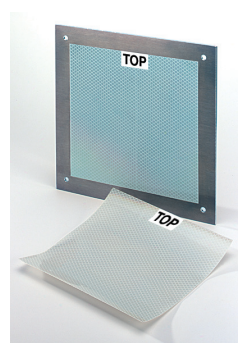

Figure 6.1: Dimensioned drawing of reflectors

Article	Reflective tape (mm)		Reflector plate (mm)		
	xL	yL	XL	YL	L
Reflective tape 200x200-M	200	200	250	250	214
Reflective tape 500x500-M	500	500	550	550	514
Reflective tape 914x914-M	914	914	964	964	928

6.2.4 Technical data of heated reflectors

The reflective tape is affixed to a heated, thermally insulated carrier. The insulation results in a very high energetic efficiency.

Only the reflective tape is kept at the specified temperature by the integrated heater. The insulation on the back prevents the generated heat from being dissipated via the steel construction. Energy costs are greatly reduced in the case of continuous heating.

Type designation	Article		
	Reflective tape 200x200-H	Reflective tape 500x500-H	Reflective tape 914x914-H
Part no.	50115020	50115021	50115022
Voltage supply	230 VAC		
Power	100W	600W	1800W
Current consumption	~ 0.5A	~ 3A	~ 8A
Length of supply line	2 m		
Size of reflective tape	200 x 200mm	500 x 500mm	914 x 914mm
Outer dimensions of base material	250 x 250mm	550 x 550mm	964 x 964mm
Weight	0.5kg	2.5kg	12kg
Temperature control	Controlled heating with the following switch-on and switch-off temperatures, measured at the reflector surface.		
Switch-on temperature	~ 5°C		
Switch-off temperature	~ 20°C		
Operating temperature	-30°C ... +70°C		
Storage temperature	-40°C ... +80°C		
Air humidity	Max. 90%, non-condensing		
Cleaning	Do not use any abrasive agents. A conventional household detergent can be used as a cleaning agent. Rinse with clear water and dry the surface.		
Reflector storage	Store in a cool and dry place.		

6.2.5 Dimensioned drawing of heated reflectors

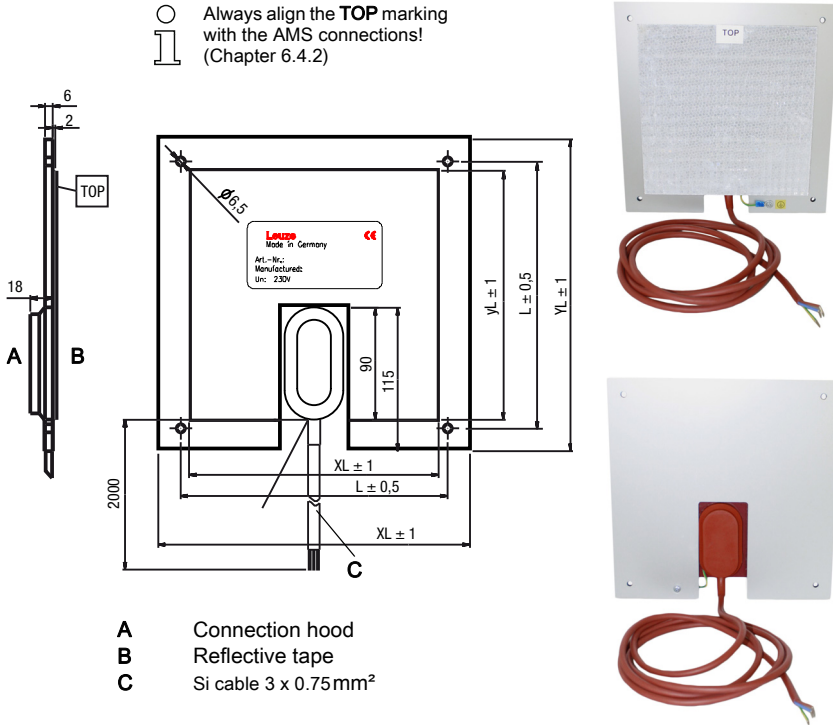

Figure 6.2: Dimensioned drawing of heated reflectors

Article	Reflective tape (mm)		Insulated carrier plate (mm)		
	xL	yL	XL	YL	L
Reflective tape 200x200-H	200	200	250	250	214
Reflective tape 500x500-H	500	500	550	550	514
Reflective tape 914x914-H	914	914	964	964	928

6.3 Selecting reflector size

Depending on the system design, the reflector can be mounted so that it moves with the vehicle or it can be mounted at a fixed location.



Attention!

The reflector sizes shown below are a recommendation from Leuze for on-vehicle mounting of the AMS 358*i*. For stationary mounting of the AMS 358*i*, a smaller reflector is generally sufficient for all measurement distances. For this reason, two smaller reflector sizes are available in the self-adhesive variant "-S".

During system planning and design, always check whether mechanical travel tolerances require the use of a reflector larger than that which is recommended. This applies, in particular, when the laser measurement system is mounted on a vehicle. During travel, the laser beam must reach the reflector unobstructed. For on-vehicle mounting of the AMS 358*i*, the reflector size must accommodate any travel tolerances that may arise and the associated "wandering" of the light spot on the reflector.

Overview of reflector types

Recommended reflector size			
Selected AMS 358 <i>i</i> (operating range in m)	Recommended reflector size (H x W)	Type designation ...-S = self-adhesive ...-M = Carrier plate ...-H = heating	Part no.
AMS 358 <i>i</i> /40 (max. 40m)	200x200mm	REF 4-A-150x150 ¹⁾ Reflective tape 200x200-S Reflective tape 200x200-M Reflective tape 200x200-H REF 4-A-300x300 ¹⁾	50141015 50104361 50104364 50115020 50141014
AMS 358 <i>i</i> /120 (max. 120m)	500x500mm	Reflective tape 500x500-S Reflective tape 500x500-M Reflective tape 500x500-H	50104362 50104365 50115021
AMS 358 <i>i</i> /200 (max. 200m)	749x914mm 914x914mm	Reflective tape 749x914-S Reflective tape 914x914-M Reflective tape 914x914-S Reflective tape 914x914-H	50104363 50104366 50108988 50115022
AMS 358 <i>i</i> /300 (max. 300m)	749x914mm 914x914mm	Reflective tape 749x914-S Reflective tape 914x914-M Reflective tape 914x914-S Reflective tape 914x914-H	50104363 50104366 50108988 50115022

1) For landside mounting

6.4 Mounting the reflector

6.4.1 General information

Self-adhesive reflective tapes

The reflective tapes of the "Reflective tape ...x...-S" series (self-adhesive) must be affixed to a flat, clean and grease-free surface. We recommend using a separate carrier plate, which is to be provided on-site.

As described in Table 6.1, the reflective tape must be at an angle.

Reflective tapes on carrier plate

The reflective tapes of the "Reflective tape ...x...-M" series have corresponding mounting holes. Spacer sleeves are provided to enable mounting at the necessary pitch angle. For further information, see Table 6.1.

Heated reflectors

The reflective tapes of the "Reflective tape ...x...-H" series have corresponding mounting holes. Due to the voltage supply affixed on the rear, the reflector cannot be mounted flat. Four spacer sleeves in two different lengths are supplied. Use the spacer sleeves to ensure separation from the wall as well as to provide the necessary pitch for avoiding surface reflection. For further information, see Table 6.1.

The reflector has a 2m-long connection cable for supplying with 230VAC. Connect the cable to the nearest power distribution point. Observe the current consumptions listed in the technical data.



Attention!

Connection work must be carried out by a certified electrician.

6.4.2 Mounting the reflector

The combination of laser measurement system and reflective tape/reflector is mounted so that the laser light spot hits the film as centered as possible and without obstruction.

For this purpose, use the alignment elements provided on the AMS 358*i*.. (see chapter 5.2 "Mounting the AMS 358i"). If necessary, remove the protective film from the reflector.



Attention!

The "TOP" label on the reflectors should be aligned the same as the connections of the AMS 358*i*.

Example:

If the AMS 358i is mounted so that the M12 connections are on the top, the "TOP" label of the reflector is also on the top. If the AMS 358i is mounted so that the M12 connections are on the side, the "TOP" label of the reflector is also on the side.



Note!

The reflector must be positioned at an angle. Use the spacer sleeves for this purpose. Angle the reflector so that the **surface reflections of the foil seal are deflected to the left, right or upwards**. Chapter 6.4.3 gives the correct pitch with respect to the reflector size and, thus, the length of the spacers.

Reflective tapes ...-S and ...-M

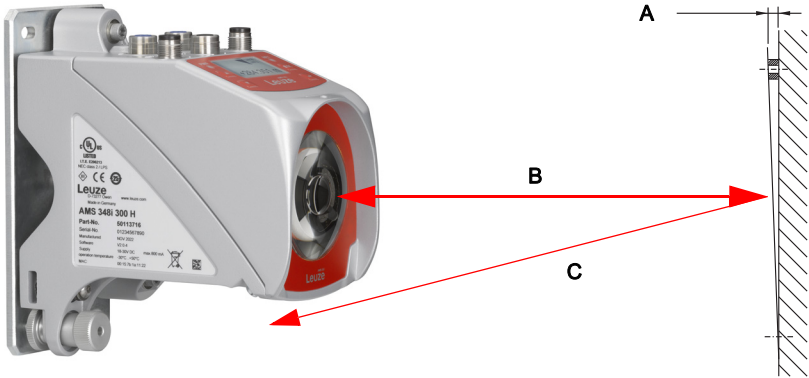

- A** Pitch approx. 1°
- B** Direct reflection due to the triple structure
- C** Deflected surface reflection due to the pitch of the reflective tape

Figure 6.3: Mounting the reflector

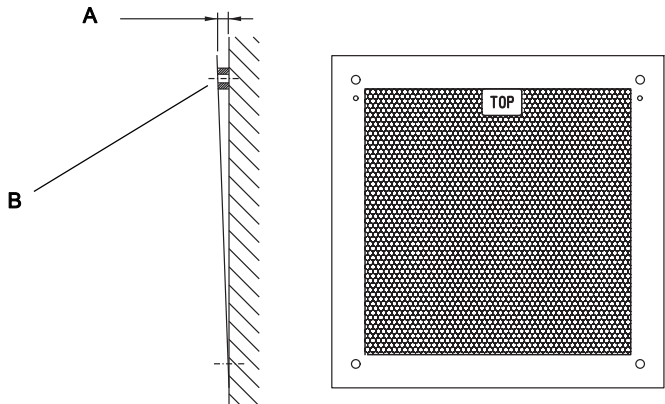

- A** Pitch approx 1°
- B** Spacer sleeves

Figure 6.4: Pitch of the reflector

Reflective tapes ...-H

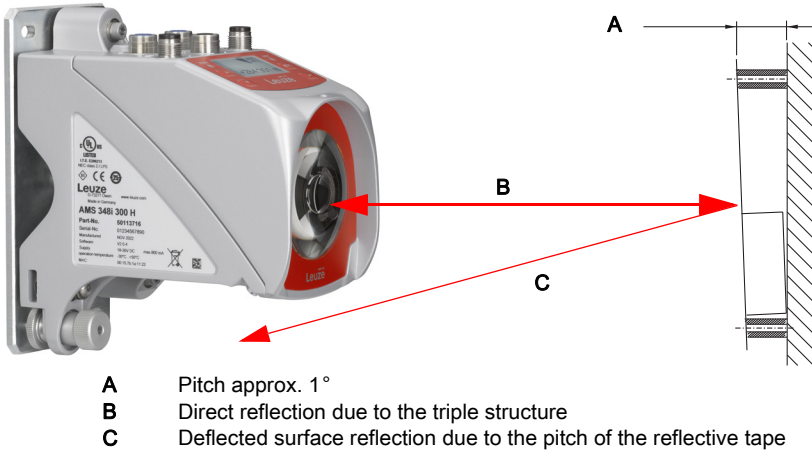

Figure 6.5: Mounting of heated reflectors

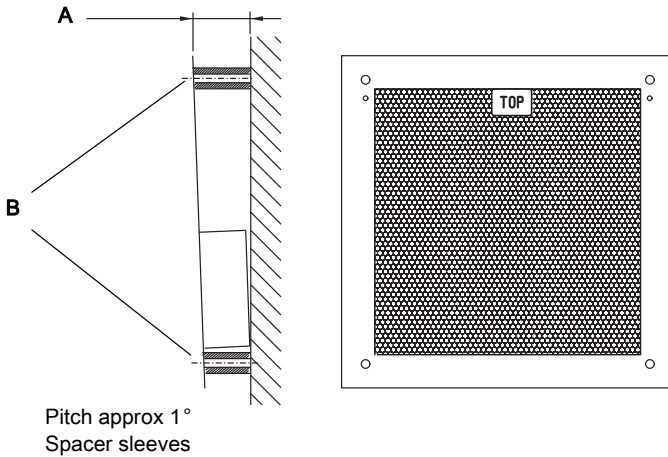

Figure 6.6: Pitch of the heated reflector

6.4.3 Table of reflector pitches

Reflector type	Pitch resulting from spacer sleeves ¹⁾	
Reflective tape 200x200-S Reflective tape 200x200-M	2 x 5mm	
Reflective tape 200x200-H	2 x 15mm	2 x 20mm
Reflective tape 500x500-S Reflective tape 500x500-M	2 x 10mm	
Reflective tape 500x500-H	2 x 15mm	2 x 25mm
Reflective tape 749x914-S	2 x 20mm	
Reflective tape 914x914-S Reflective tape 914x914-M	2 x 20mm	
Reflective tape 914x914-H	2 x 15mm	2 x 35mm

1) Spacer sleeves are included with reflective tape ...-M and ...-H

Table 6.1: Reflector pitch resulting from spacer sleeves



Note!

Reliable operation of the AMS 358*i* and, thus, max. operating range and accuracy can only be achieved with the reflective tape specified by Leuze. Correct operation cannot be guaranteed if other reflectors are used!

7 Electrical connection

The AMS 358*i* laser measurement systems are connected using variously coded M12 connectors. This ensures unique connection assignments.



Note!

The corresponding mating connectors and ready-made cables are available as accessories for all connections. For further information, see chapter 11 "Type overview and accessories".

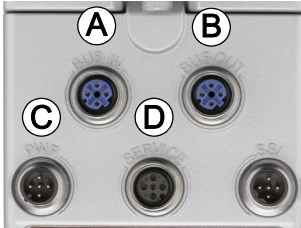

- | | |
|----------|-------------------------------------|
| A | BUS IN, M12 socket (D-coded) |
| B | BUS OUT, M12 socket (D-coded) |
| C | PWR / IOs, M12 connector (A-coded) |
| D | Leuze SERVICE, M12 socket (A-coded) |

Figure 7.1: Connections of the AMS 358*i*

7.1 Safety notices for the electrical connection



Attention!

Before connecting the device, be sure that the supply voltage agrees with the value printed on the name plate.

The device may only be connected by a qualified electrician.

Ensure that the functional earth (FE) is connected correctly. Unimpaired operation is only guaranteed when the functional earth is connected properly.

If faults cannot be cleared, the device should be switched off and protected against accidental use.



Attention!

For UL applications, use is only permitted in Class 2 circuits in accordance with the NEC (National Electric Code).



The laser measurement systems are designed in accordance with protection class III for supply by PELV (protective extra-low voltage with reliable disconnection).



Note!

Degree of protection IP65 is achieved only if the connectors and caps are screwed into place!

Described in detail in the following are the individual connections and pin assignments.

7.2 PWR – voltage supply / switching input/output

PWR (5-pin connector, A-coded)			
<p>PWR</p> <p>I/O 1</p> <p>2</p> <p>GND 3</p> <p>5</p> <p>FE 4</p> <p>I/O 2</p> <p>M12 connector (A-coded)</p>	Pin	Name	Comment
	1	VIN	Positive supply voltage +18 ... +30VDC
	2	I/O 1	Switching input/output 1
	3	GNDIN	Negative supply voltage 0VDC
	4	I/O 2	Switching input/output 2
	5	FE	Functional earth
	Thread	FE	Functional earth (housing)

Table 7.1: Pin assignments - PWR

Further information on configuring the input/output can be found in Chapter 8 and Chapter 9.

7.3 EtherNet/IP BUS IN

BUS IN (4-pin socket, D-coded)			
<p>BUS IN</p> <p>RD+</p> <p>2</p> <p>TD+ 1</p> <p>3 TD-</p> <p>4</p> <p>RD-</p> <p>M12 socket (D-coded)</p>	Pin	Name	Comment
	1	TD+	Transmit Data +
	2	RD+	Receive Data +
	3	TD-	Transmit Data -
	4	RD-	Receive Data -
Thread	FE	Functional earth (housing)	

Table 7.2: BUS IN pin assignment

7.4 EtherNet/IP BUS OUT

BUS OUT (4-pin socket, D-coded)			
BUS OUT	Pin	Name	Comment
 <p>M12 socket (D-coded)</p>	1	TD+	Transmit Data +
	2	RD+	Receive Data +
	3	TD-	Transmit Data -
	4	RD-	Receive Data -
	Thread	FE	Functional earth (housing)

Table 7.3: Pin assignment BUS OUT

7.5 Service

Service (5-pin socket, A-coded)			
SERVICE	Pin	Name	Comment
 <p>M12 socket (A-coded)</p>	1	NC	Not assigned
	2	RS232-TX	Transmission line RS 232/service data
	3	GND	Voltage supply 0VDC
	4	RS232-RX	Receiving line RS 232/service data
	5	NC	Not used
	Thread	FE	Functional earth (housing)

Table 7.4: Pin assignment - Service

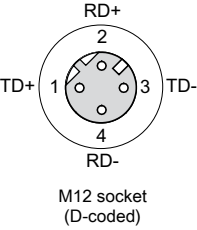

Note!

The service interface is designed only for use by Leuze!

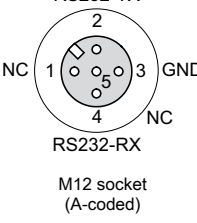
8 Display and control panel AMS 358i

8.1 Structure of the control panel

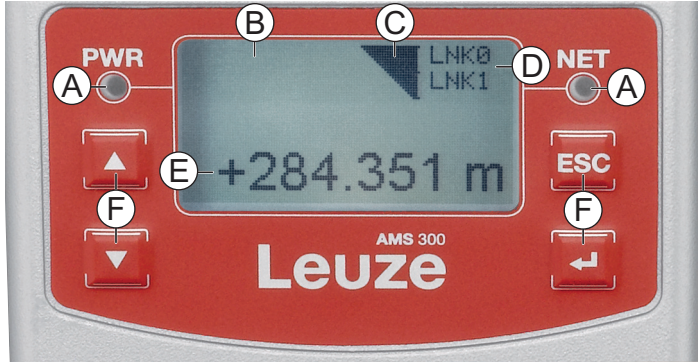

- A LED
- B Status indicator
- C Bargraph
- D Bus/interface info
- E Distance measurement value
- F Control buttons

Figure 8.1: Structure of the control panel using the AMS 304i/PROFIBUS device variant as an example

8.2 Status indicators and operation

8.2.1 Indicators in the display

Status and warning messages in the display

- IO1 **Input 1 or output 1 active:**
Function depending on configuration.
- IO2 **Input 2 or output 2 active:**
Function depending on configuration.
- LSR **Warning - laser prefailure message:**
Laser diode old, device still functional, exchange or have repaired.
- TMP **Warning - temperature monitoring:**
Internal device temperature above/below permissible range.
- PLB **Plausibility error:**
Implausible measurement value. Possible causes: light beam interruption, outside of measurement range, permissible internal device temperature considerably exceeded or traverse rate >10m/s.

Depending on the configuration, either zero or the last valid measurement value is output at the interfaces.

ATT Warning - received signal:

Laser exit window or reflector soiled or fogged by rain, water vapor or fog. Clean or dry surfaces.

ERR Internal hardware error:

The device must be sent in for inspection.

Bar graph



Indicates the **strength of the received laser light**.

The center bar represents the **ATT** warning threshold. The distance value remains valid and is output at the interfaces.

If no bar graph is available, the **PLB** status information appears at the same time.

The measurement value is assessed as implausible. Depending on the configuration, either zero or the last valid measurement value is output at the interfaces.

Interface info

An activated EtherNet/IP interface is indicated in the display by means of code "ENIP".

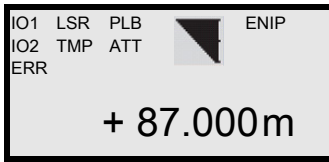

← ENIP
Activated interface

← Position value

Position value

The measured position value is displayed in the configured unit of measurement.

+87.000m With the **metric** setting, the measurement value is always displayed in meters to **three decimal places**.

+87.0in With the **inch** setting, the measurement value is always displayed in inches to **one decimal place**.

8.2.2 LED status indicators

After power ON, the Power LED and Net LED are tested as follows:

1. LEDs off.
2. LEDs are switched to green for approx. 0.25s.
3. LEDs are switched to red for approx. 0.25s.
4. LEDs off.

This is followed by the status display for the Power LED (see chapter 9.3) and the Net LED.

PWR LED

PWR

**Off****Device OFF**

- No supply voltage

PWR

**Flashing green****Power LED flashes green**

- LED function test for 0.25s after power up
- No measurement value output
- Voltage connected
- Self test running
- Initialization running
- Parameter download running
- Boot process running

PWR

**Green continuous light****Power LED green**

- AMS 358*i*/OK
- Measurement value output
- Self test successfully finished
- Device monitoring active

PWR

**Red flashing****Power LED flashes red**

- LED function test for 0.25s after power up
- Device OK but warning message (ATT, TMP, LSR) set in display
- Light beam interruption
- Plausibility error (PLB)

PWR

**Red continuous light****Power LED red**

- No measurement value output; for details, see display

NET LED

Net



Off

NET LED off

- No voltage supply
- No IP address assigned (BootP, DHCP)

Net



Green, flashing

NET LED flashes green

- LED function test for 0.25s after power up
- no EtherNet/IP communication present
- AMS 358*i* is not assigned to a master

Net



Green, continuous light

NET LED green

- AMS 358*i* bus communication ok

Net



Red, flashing

NET LED flashes red

- LED function test for 0.25s after power up
- Time-out in bus communication

Net



Red, continuous light

NET LED red

- Double IP address

Net



Green/red, flashing

NET LED flashes green/red

- Self test

LINK LED for BUS IN and BUS OUT

A green/yellow multicolor LED below the BUS IN and BUS OUT connectors indicates the EtherNet/IP connection status.



Green continuous light

LINK LED green

- The link exists, the hardware connection to the next connected participant is OK.







Flashing yellow



LINK LED flashes yellow

- Data is exchanged with the connected participants.

8.2.3 Control buttons

-  **Up** Navigate upward/sideways.
-  **Down** Navigate downward/sideways.
-  **ESC** Exit menu item.
-  **ENTER** Confirm/enter value, change menu levels.

Navigating within the menus

The menus within a level are selected with the up/down buttons  .

The selected menu item is activated with the enter button .





Press the ESC button  to move up one menu level.



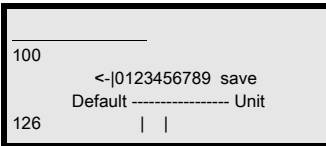

When one of the buttons is actuated, the display illumination is activated for 10 min.



Setting values

If input of a value is possible, the display looks like this:



-  +  Delete character
-  +  Enter digit
- save** +  Save



Use the   and  buttons to set the desired value. An accidental, incorrect entry can be corrected by selecting <-| and then pressing .

Then use the   buttons to select save and save the set value by pressing .

Selecting options

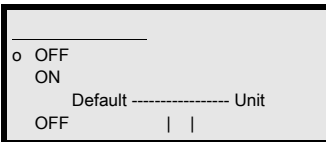
If options can be selected, the display looks like this:



Select the desired option with the   buttons. Activate the option by pressing .

8.3 Menu description

8.3.1 The main menus

After voltage has been applied to the laser, device information is displayed for several seconds. The display then shows the measurement window with all status information.

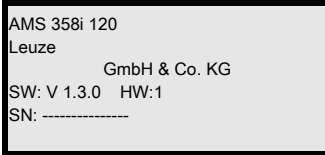

Device information - main menu

This menu item contains detailed information on

- Device type
- Manufacturer
- Software and hardware version
- Serial number

No entries can be made via the display.

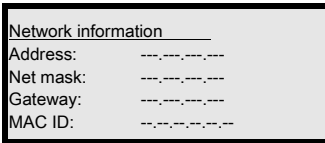

Network information - main menu

- Display of the network settings.

No entries can be made via the display.

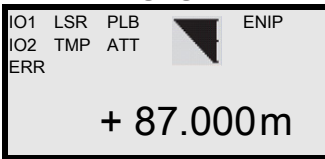

Status and measurement data - main menu

- Display of status, warning and error messages.
- Status overview of the switching inputs/outputs
- Bar graph for the received signal level.
- Link
- Measurement value

No entries can be made via the display.

See "Indicators in the display" on page 43.

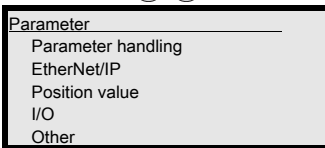

Parameter - main menu

- Configuration of the AMS.

See "Parameter menu" on page 49.

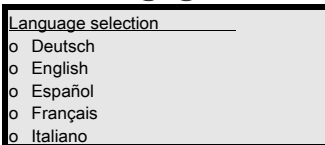

Language selection - main menu

- Selection of the display language.

See "Language selection menu" on page 53.

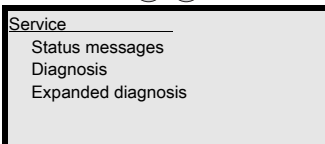

Service - main menu

- Display of status messages.
- Display of diagnostic data.

No entries can be made via the display.

See "Service menu" on page 53.



Note!

The rear cover of this manual includes a **fold-out page** with the complete **menu structure**. It describes the menu items in brief.

8.3.2 Parameter menu

Parameter handling submenu

The following functions can be called up in the Parameter handling submenu:

- Lock and enable parameter entry
- Set up a password
- Reset the AMS 358*i* to the default settings

Table 8.1: Parameter handling submenu

Level 3	Level 4	Level 5	Selection/configuration option Description	Standard
Parameter enable			ON/OFF The standard setting (OFF) prevents unintended parameter changes. With parameter enable activated (ON), the display is inverted. In this state, it is possible to change parameters manually.	OFF
Password	Activate password		ON/OFF To enter a password, parameter enable must be activated. If a password is assigned, changes to the AMS 358 <i>i</i> can only be made after the password is entered. The master password 2301 overrides the individually set password.	OFF
	Password entry		For setting a four-digit numerical password.	
Parameters to default			By pressing the enter button  after selecting Parameters to default, all parameters are reset to their standard settings without any further security prompts. In this case, English is selected as the display language.	

Additional important information on parameter handling can be found at the end of the chapter.

EtherNet/IP submenu

Table 8.2: EtherNet/IP submenu

Level 3	Level 4	Level 5	Selection/configuration option Description	Standard
Activation			ON/OFF	
Ethernet interface	Address	Address	The IP address can be set to any value in the format ---.---.- ---.---. Normally, the network administrator specifies the IP address that is to be set here. If DHCP is activated, the setting made here has no effect and the AMS 358 <i>i</i> is set to the values that it obtains from the DHCP server.	

Table 8.2: EtherNet/IP submenu

Level 3	Level 4	Level 5	Selection/configuration option Description	Standard
	Gateway		The gateway address can be set to any value in the format ---.---.---.---. The AMS 358/ communicates with participants in other subnets via the gateway. Splitting the read application over multiple subnets is rather uncommon; the setting of the gateway address, thus, usually has no meaning.	
	Net mask		The net mask can be set to any value in the format ---.---.---.---. Usually, the AMS 358/ is used in a private Class C network and the default setting can be accepted without change. Attention: It is possible to enter any values for ---.---.---.---. Only the values 255 or 000 are permissible for ---, however. If other values are set, an error message appears upon restart of the AMS 358/.	
	DHCP activated		ON/OFF If DHCP is activated, the AMS 358/ obtains its settings for IP address, gateway and net mask from a DHCP server. The manual settings made above have no effect, but are retained and are again active if DHCP is deactivated.	ON
	BootP activated		ON/OFF If BootP is activated, the AMS 358/ obtains its settings for IP address, gateway and net mask from a BootP server. The manual settings made above have no effect, but are retained and are again active if BootP is deactivated.	OFF

Position value submenu

Table 8.3: Position value submenu

Level 3	Level 4	Level 5	Selection/configuration option Description	Standard
	Unit		Metric/Inch Specifies the units of the measured distances	Metric
	Counting direction		Positive/Negative Positive: The measurement value begins at 0 and increases with increasing distance. Negative: The measurement value begins at 0 and decreases with increasing distance. Negative distance values may need to be compensated with an offset or preset.	Positive
	Offset		Output value = measurement value + offset The resolution of the offset value is independent of the selected "Position resolution" and is entered in mm or inch/100. The offset value is effective immediately after entry. If the preset value is activated, this has priority over the offset. Preset and offset are not offset against each other.	0 mm
	Preset		The preset value is accepted by means of teach pulse. The teach pulse can be applied to a hardware input of the M12 PWR connector. The hardware input must be appropriately configured. See also configuration of the I/Os.	0 mm
	Free resolution value		The measurement value can be resolved in increments of 1/1000 within the 5 ... 50000 value range. If e.g. a resolution of 0.875 mm per digit is required, the parameter is set to 875.	1000

Table 8.3: Position value submenu

Level 3	Level 4	Level 5	Selection/configuration option Description	Standard
Error delay			ON/OFF Specifies whether, in the event of an error, the position value immediately outputs the value of the "Position value in the case of failure" parameter or the last valid position value for the configured error delay time.	ON/100 ms
Position value in the case of failure			Last valid value / zero Specifies which position value is output after the error delay time elapses.	Zero

I/O submenu

Table 8.4: I/O submenu

Level 3	Level 4	Level 5	Selection/configuration option Description	Standard
I/O 1	Port configuration		Input/Output Defines whether I/O 1 functions as an output or input.	Output
	Switching input	Function	No function/teach preset/laser ON/OFF	No function
		Activation	Low active/High active	Low active
	Switching output	Function	Pos. limit value 1 / Pos. limit value 2 / Velocity / Intensity (ATT) / Temp. (TMP) / Laser (LSR) / Plausibility (PLB) / Hardware (ERR) The individual functions are "ORed" on the selected switching output.	Plausibility (PLB), hardware (ERR)
		Activation	Low active/High active	Low active
I/O 2	Port configuration		Input/Output Defines whether I/O 2 functions as an output or input.	Output
	Switching input	Function	No function/teach preset/laser ON/OFF	No function
		Activation	Low active/High active	Low active
	Switching output	Function	Pos. limit value 1 / Pos. limit value 2 / Velocity / Intensity (ATT) / Temp. (TMP) / Laser (LSR) / Plausibility (PLB) / Hardware (ERR) The individual functions are "ORed" on the selected switching output.	Intensity (ATT), Temp. (TMP), Laser (LSR)
		Activation	Low active/High active	Low active
Limit values	Upper pos. limit 1	Activation	ON/OFF	OFF
		Limit value input	Value input in mm or inch/100	0
	Lower pos. limit 1	Activation	ON/OFF	OFF

Table 8.4: I/O submenu

Level 3	Level 4	Level 5	Selection/configuration option Description	Standard
		Limit value input	Value input in mm or inch/100	0
	Upper pos. limit 2	Activa-tion	ON/OFF	OFF
		Limit value input	Value input in mm or inch/100	0
	Lower pos. limit 2	Activa-tion	ON/OFF	OFF
		Limit value input	Value input in mm or inch/100	0

Other submenu

Table 8.5: Other submenu

Level 3	Level 4	Level 5	Selection/configuration option Description	Standard
Heating control			Standard (10°C ... 15°C)/Extended (30°C ... 35°) Defines a switch-on/switch-off range for the heating control. The extended switch-on/switch-off range for heating may provide a remedy in the event of condensation problems. Due to the limited heating capacity, it cannot be guaranteed that no condensation will form on the optics in the extended switch-on/switch-off range. This parameter is available as standard, but functions only for devices with integrated heating (AMS 358 <i>/... H</i>).	Standard
Display illumination			10 minutes/ON Display illumination is switched off after 10 minutes or, if the parameter is set to "ON", illumination is always on.	10min
Display contrast			Weak/Medium/Strong The display contrast may change at extreme temperature values. The contrast can subsequently be adapted using the three levels.	Medium
Service RS232	Baud rate		57.6kbit/s / 115.2kbit/s The service interface is only available to Leuze personnel.	115.2kbit/s
	Format		8,e,1 / 8,n,1 The service interface is only available to Leuze personnel.	8,n,1

8.3.3 Language selection menu

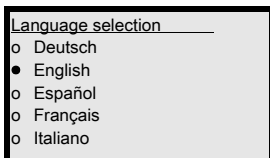

5 display languages are available:

- German
- English
- Spanish
- French
- Italian

The AMS 358*i* is delivered from the factory with the display preset to English.

To change the language, no password needs to be entered nor must parameter enable be active. The display language is a passive operational control and is therefore not a function parameter per se.

8.3.4 Service menu

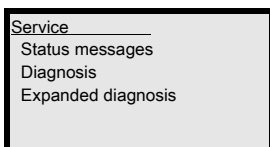

A detailed description of the individual functions can be found in Chapter 10.

8.4 Operation

An operating process is described here using parameter enable as an example.

Parameter enable

During normal operation parameters can be viewed only. If parameters are to be changed, the ON menu item in the Parameter -> Parameter handling -> Parameter enable menu must be activated. To do this, proceed as follows.

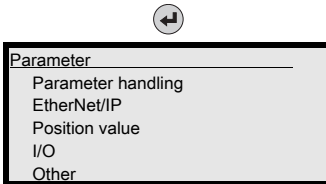

In the main menu, press the enter button to enter the Parameter menu.

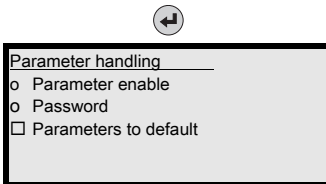

Use the ▲▼ buttons to select the Parameter handling menu item.

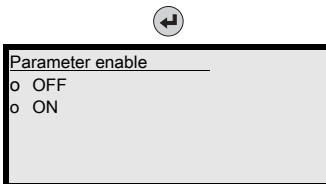

Press the enter button to enter the Parameter handling menu.

In the Parameter handling menu, use the ▲▼ buttons to select the Parameter enable menu item.

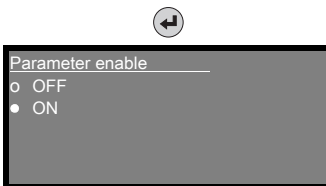

Press the enter button to enter the Parameter enable menu.

In the Parameter enable menu, use the ▲▼ buttons to select the ON menu item.

Press the enter button to activate parameter enable.

The PWR LED lights up orange; the display is inverted. You can now set the individual parameters on the display.



Press the ESC button twice to return to the Parameter menu.



Viewing and editing parameters

As long as parameter enable is active, the entire AMS 358/i display is inverted.

As long as parameter enable is active, communication between control and AMS 358/i is interrupted. The extended networking via BUS OUT is retained.

**Attention!**

The AMS 358i offers a configuration assembly. If this is activated in the control, all parameters are to be entered there.

The configuration assembly is automatically downloaded to the AMS according to the criteria of the respective control.

This results in parameters that were manually changed via the display/panel being restored by the control to the configured Configuration assembly. The parameters that were manually changed via the display are, thus, no longer valid.

The address setting performed on the AMS 358i for EtherNet/IP is not affected by the automatic parameter download performed by the control.

**Attention!**

If the Configuration Assembly function is not activated, parameters set manually via the display are activated the moment parameter enabling is again deactivated on the AMS 358i.

**Note!**

If a password was stored, parameter enable is not possible until this password is entered; see "Password for parameter enable" below.

Password for parameter enable

Parameter entry on the AMS 358i can be protected with a password. With the AMS 358i, the password is defined via the EDS file (class 100, instance 1) or the configuration assembly. Therefore, the password cannot be changed by means of display entry.

To activate parameter enabling via the display (e.g., to enter an IP address), the defined password must be entered via the display. If parameter enable has been activated after successfully entering the password, parameters can be temporarily changed via the display.

After parameter enable is deactivated, all changes made on the display are overwritten by the Configuration assembly (see above). If a new password has been assigned, this, too, is overwritten by the password defined in the Configuration assembly.

**Note!**

The master password 2301 can enable the AMS 358i at any time.

9 EtherNet/IP interface

9.1 EtherNet/IP – General info

EtherNet/IP is an industrial communication network based on Ethernet and builds on the TCP/IP and UDP/IP protocols.

EtherNet/IP uses **CIP (Common Industrial Protocol)** as the application layer for the user. CIP distinguishes between real-time communication by means of "implicit messages", and individual, acyclic services referred to as "explicit messages".

Explicit messages

Explicit messages are sent based on TCP/IP. The receiver interprets the message as an instruction, executes this instruction and generates a corresponding answer. Explicit messages are used e.g. for device configuration, programming and for the diagnosis and communication of non-time-critical data, and do not have real-time character.

Explicit messages are always sent after point-to-point communication.

All EDS objects of the AMS 358*i* that are described below can be called up via explicit services (e.g. Get Attribute Single, Set Attribute Single, etc.).

Implicit messages

Implicit messages are used to send real-time I/O data. For this purpose, EtherNet/IP does not use TCP, but rather UDP (User Datagram Protocol) via IP (Internet Protocol). This protocol is much more compact and supports multicast and unicast messages.

Implicit message telegrams are sent cyclically (the cycle can be configured via the control) repeatedly at short intervals with current data and I/O signals. The telegram overhead here is minimal so that these messages can be processed extremely quickly and in a prioritized manner.

Within the AMS 358*i*, the input and output assemblies for transferring measurement values are transferred by means of UDP and are therefore available deterministically in a cycle configured via the control.

For implicit messages, EtherNet/IP uses the producer/consumer communication model for data exchange. A producer is a device that sends data; a consumer is a device that receives data. In multicast mode, multiple consumers can receive and evaluate a producer message at the same time.

Generally speaking, it should be noted that if multicast is used, the messages are sent to all participants as a broadcast. This significantly increases the data traffic on the network. If the data is to be exchanged only between the AMS and PLC, we recommend that the unicast mode be set at the control for these participants.

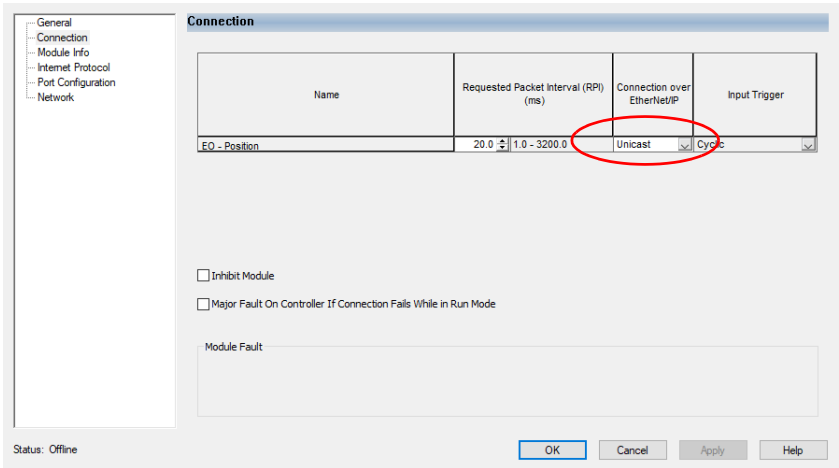

Figure 9.1: Setting unicast mode

EtherNet/IP therefore combines TCP/IP and UDP/IP data telegrams for transferring explicit and implicit messages. As a result, EtherNet/IP can use both real-time I/O data for time-critical control tasks (UDP) as well as information data (TCP) simultaneously on the same network.

All data of the AMS 358*i* is represented CIP object-oriented and is accessible to the user by means of the explicit and implicit message services described above.

The common basis for configuration within CIP is the **EDS file (Electronic Data Sheet)**. The EDS file of the AMS 358*i* contains predefined input and output assemblies for the UDP-based real-time transfer as well as all configuration and diagnostic data for the TCP/IP-based services.



Note!

*The AMS 358*i* communicates via the Common Industrial Protocol (CIP). CIP Safety, CIP Sync and CIP Motion are **not** supported by the AMS 358*i*.*

The EDS file for the AMS 358*i* can be found on the Leuze homepage www.leuze.com.

9.2 Topology

The AMS 358*i* can be used in all topologies defined by EtherNet/IP. The M12 connections for BUS IN and BUS OUT are coupled to each other via an integrated switch. The AMS 358*i* can thus be used for further branching of EtherNet/IP based on the standard CIP.

If parameter enable of the AMS 358*i* is activated via the display, the AMS 358*i* is deactivated as a participant. This avoids parameter access conflicts. In this case, it is still possible to communicate with the participant connected via BUS OUT.

**Note!**

*The AMS 358*i* does not support the DLR (Device Level Ring) ring structure determined by the ODVA.*

9.3 Addressing

Each participant connected to EtherNet/IP must be assigned an IP address. Addressing can be performed manually or automatically via DHCP or BootP.

By default, DHCP is set to "ON", BootP is set to "OFF". Both settings can be changed via the display.

**Note!**

*Basic operation of the display is described in Chapter 8.2.
To manually set the network addresses (not DHCP), parameter enable must be activated.
The display is inverted when parameter enable is active.*

**Attention!**

The laser measurement system is deactivated on the EtherNet/IP when parameter enable is activated via the display. The device is reactivated on the EtherNet/IP after parameter enable is canceled.

Address Link Label:

The "Address Link Label" is an additional stick-on label that is affixed to the device.

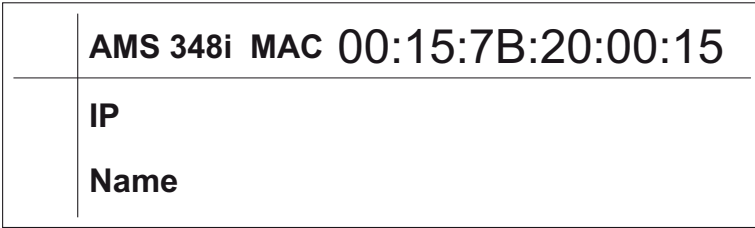

Figure 9.2: Example of an "Address Link Label"; the device type varies depending on the series

- The "Address Link Label" contains the MAC address (Media Access Control address) of the device and makes it possible to enter the IP address and the device name manually. The area of the "Address Link Label" on which the MAC address is printed can be separated from the remainder of the stick-on label if necessary using the perforation.
- The "Address Link Label" can be removed from the device and affixed in the installation and layout diagrams to designate the device.
- Once it is affixed in the documents, the "Address Link Label" establishes a unique reference between the mounting location, the MAC address or the device, and the associated control program. The time-consuming searching, reading, and manually writing down of the MAC addresses of all devices installed in the system are eliminated.



Note!

Each device with Ethernet interface is uniquely identified via the MAC address assigned during production. The MAC address is also listed on the name plate of the device. If multiple devices are commissioned in a system, the MAC address of each installed device must be correctly assigned, e.g., during programming of the control.

- ↪ *Remove the "Address Link Label" from the device.*
- ↪ *If necessary, add the IP address and the device name to the "Address Link Label".*
- ↪ *Affix the "Address Link Label" in the documents, e.g., in the installation diagram, according to the position of the device*

9.3.1 Entering the network address via the display

To do this proceed as follows:

- ↪ *Activate Parameter enable.*
- ↪ *Select the EtherNet/IP submenu.*
- ↪ *Select the IP address menu item.*
- ↪ *Enter the Ethernet IP address and save your entry with save.*

- ↳ Select the Gateway menu item.
- ↳ Enter the Gateway address and save your entry with save.
- ↳ Select the Net mask menu item.
- ↳ Enter the address of the net mask and save your entry with save.
- ↳ Deactivate parameter enable.

Manual address assignment for the IP address, net mask (subnet) as well as a gateway (if present) is shown in the structure below.

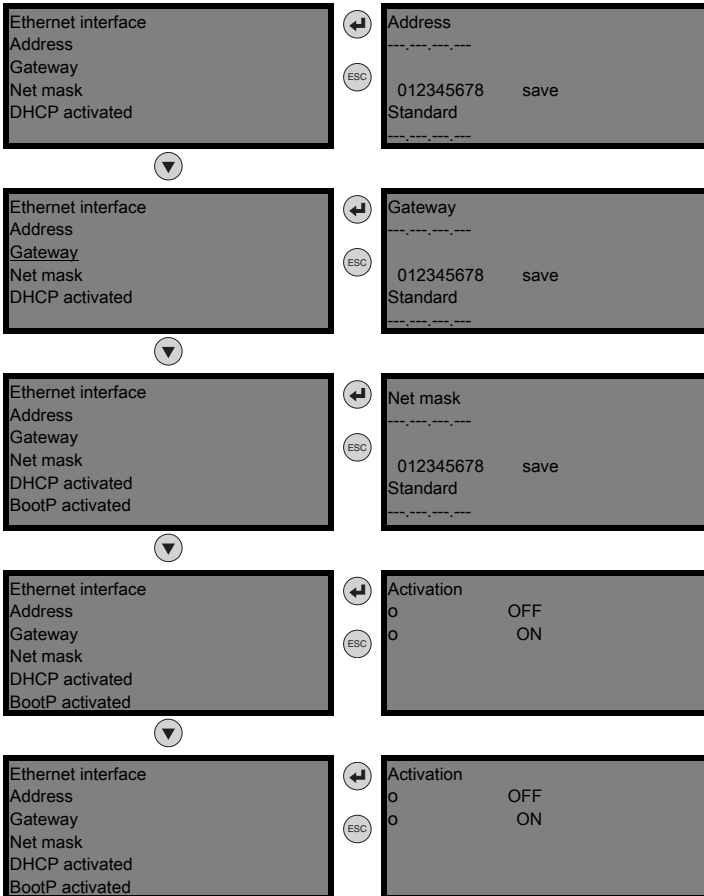

The complete menu structure can be found at the end of the description.

The complete addressing including the MAC ID can be called up via the main menu mask Network information.

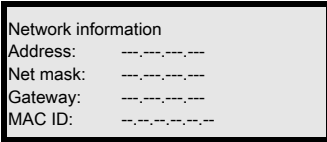

9.4 EtherNet/IP device class

EtherNet/IP defines four different device classes. The basis for this is the fundamental behavior of the devices, their intended application and the product type assigned to a device class.

The device class in turn defines the supported EtherNet/IP communication. The device class indicates whether explicit and implicit messages can be exchanged with the participant.

The device classes are divided into server, client, adapter and scanner.

The AMS 358/i is assigned to the "adapter" device class and can therefore receive and send implicit as well as explicit messages.

9.4.1 Communication / EDS file

The EDS file is part of the AMS 358/i. All data of the AMS 358/i can be called up via the object, instance and attribute addresses described below.

The EDS file provides input and output assemblies for implicit (real-time) communication as well as a configuration assembly for all device parameters.

All data can also be called up via explicit calls.



Note!

The possibility of integrating the EDS file in the control is not standardized. Check with your control manufacturer whether integration in the control is supported.

The EDS file can if required be downloaded from the Leuze homepage www.leuze.com.

The data is addressed according to the following fundamental scheme:

1. Device address (IP address)
The participant is addressed with its IP address, which is unique in the network.
2. Object class identifier (class)
Used as the basis for addressing the desired object class.
3. Object instance identifier (instance)
Addressing of the object instance within the object class.

4. Attribute identifier (attribute)
Addressing of the attribute within the object instance.
5. Service code (get, set, reset, start, stop and others...)
The service code ultimately describes the type of access to the data, e.g., reading or writing.

9.5 EtherNet/IP - Electrical connection

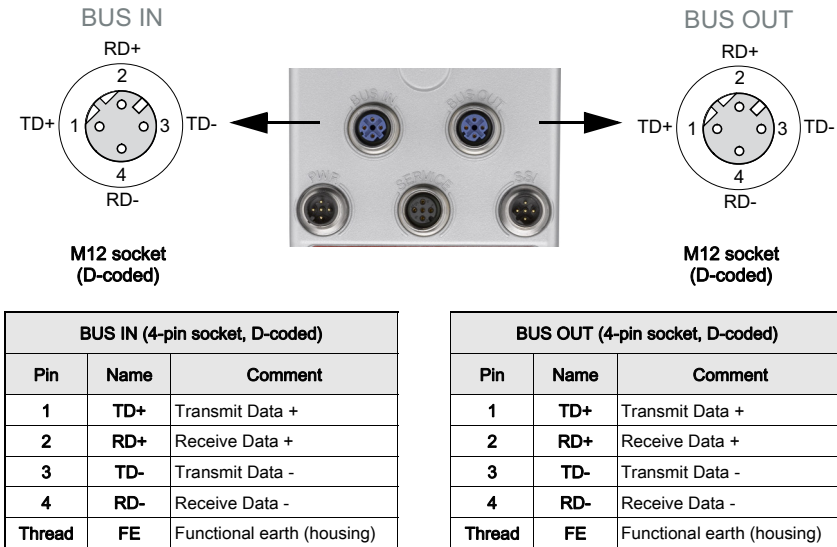

Figure 9.3: EtherNet/IP - Electrical connection



Note!

For connecting **BUS IN** and **BUS OUT**, we recommend our ready-made Ethernet cables (see chapter 11.4.5 "Accessories - Ready-made cables for EtherNet/IP").

9.6 EDS file - general info

An EDS file (Electronic Data Sheet) is provided for the AMS 358*i*.

The EDS file is named "AMS358i.eds"; the corresponding icon is named "AMS358i.ico"

Both files can be downloaded at the Leuze homepage www.leuze.com.

The EDS file contains all identification and communication parameters of the device, as well as the available objects.

The AMS 358*i* is uniquely classified via a class 1 identity object (component of the AMS358i.eds file) for the EtherNet/IP scanner (master).

The identity object contains, among other things, a manufacturer-specific Vendor ID, as well as an ID that describes the principle function of the participant.

The AMS 358*i* has the following identity object (class 1):

Vendor ID: 524_{Dec} / 20C_H

Device type: 34_{Dec} / 22_H (identifies the AMS 358*i* as an "encoder")

Position sensor type: 8_{Dec} / 8_H (specifies the AMS 358*i* as an "absolute encoder")

If accepting the objects without change, all parameters are set to default values. The default settings are shown in the objects described in detail in the "Default" column.

An assembly is activated by default in the EDS file. The assembly automatically communicates its inputs and outputs to the control. Further information on the assemblies can be found in Chapter 9.10.1.



Note!

In the following tables, all attributes marked in the "Access" column with "Get" in the individual objects are to be understood as inputs of the scanner (control). E.g. "Read in the position value" --> Class 35; instance 1; attribute 10.

Attributes marked in the "Access" column with "Set" represent outputs or parameters. Outputs are set, e.g. "Laser off"--> Class 35; instance 1; attribute 110.

Parameters are also marked with "Set" and written to the AMS. E.g. "Change the position format" --> Class 35; instance 1; attribute 15.

The setting of attributes only becomes effective after the device has been restarted. Only the following attributes are directly changed/adopted during runtime:

Position format	Class 35	Instance 1	Attribute 15
Velocity format	Class 35	Instance 1	Attribute 25
Free resolution	Class 35	Instance 1	Attribute 107
Language selection	Class 100	Instance 1	Attribute 1

All other attributes only become active after the device is restarted.

If no restart is performed after changes are made, the changes will not be adopted.

The EDS file is described in detail below. The access addresses to the individual objects as well as the default settings of the individual attributes are given in this description.

Furthermore, assemblies with predefined inputs and outputs are provided for implicit (real-time) communication. A detailed description of the assemblies can be found in Chapter 9.10.

The EDS file also contains a configuration assembly. The configuration assembly is used for storing parameters of the AMS 358*i* in the control.

For this purpose, a separate storage place for each participant must be provided in the control.

If a "generic module" is used in the control for the configuration assembly, then all memory locations are preset with parameter values 0 (zero). When using the generic module, it is, therefore, mandatory that the individual parameters be transferred by hand from the manual (see chapter 9.10.1.6 "Configuration assembly").

9.7 Configuration steps for a Rockwell control without EDS support

9.7.1 Integrating the hardware into the PLC using the generic Ethernet module

In the **RSLogix 5000** configuration tool (up to software version **20.00**), a so-called **generic Ethernet module** is created under the Communication path for the AMS 358*i*.

The screenshot shows the 'New Module' dialog box with the following configuration:

- Type: ETHERNET-MODULE Generic Ethernet Module
- Vendor: Rockwell Automation/Allen-Bradley
- Parent: Local
- Name: AMS_358i
- Description: (empty)
- Comm Format: Data - DINT
- Address / Host Name:
 - IP Address: 192 . 168 . 1 . 101
 - Host Name: (empty)
- Connection Parameters:

	Assembly Instance:	Size:
Input:	1	1 (32-bit)
Output:	120	2 (32-bit)
Configuration:	190	0 (8-bit)
Status Input:		
Status Output:		

At the bottom, there is a checkbox for 'Open Module Properties' (checked), and buttons for 'OK', 'Cancel', and 'Help'.

Figure 9.4: Generic Ethernet module

The input mask for the generic module describes the following parameters to be set:

- The name of the participant (can be selected freely; e.g. AMS 358*i*)
- The format of I/O data (data - SINT = 8 bits)
- The IP address of the participant
- The address and length of the input assembly (instance 100, instance 101 or instance 102; min 1 byte - up to max. 266 bytes for the default input assembly of the read results).
- The address and length of the output assembly (instance 120, instance 121 or instance 122; min 1 byte - up to max. 263 bytes for the default output assembly)
- The address and length of the configuration assembly (instance 190; 3 bytes)

9.8 Configuration steps for a Rockwell control with EDS support

The following steps are necessary for commissioning with a Rockwell control:

- Creation of the EtherNet/IP participants in PLC software **RSLogix 5000 from version 20.00 and up** (with EDS support).
- Installation of the EDS file using the EDS wizard.
- Setting the parameters of the AMS 358*i* via the configuration assembly or webConfig.

9.8.1 Integrating the hardware into the PLC and installing the EDS file

To integrate the device and to establish a connection between the PLC and the device AMS 358*i*, proceed as follows:

- First, load the EDS file for the device **via EDS wizard** into the PLC database.



Note!

You can find the EDS file at www.leuze.com.

- After it has downloaded, select the device from the device list.
- Open the input dialog for setting the address and additional parameters by double-clicking on the device symbol and make the desired entries here. Under **Change**, define the combination of input and output assemblies.

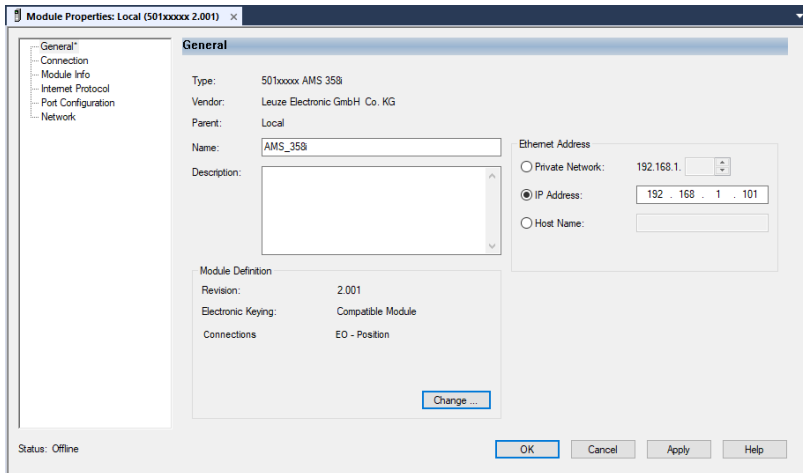

Figure 9.5: New module

- Finally, transmit the values to the control via download.

9.9 Configuration examples

9.9.1 Example 1 - RSLogix 5000 up to software version V19.xx

Configuration of a generic module without the use of the configuration assembly

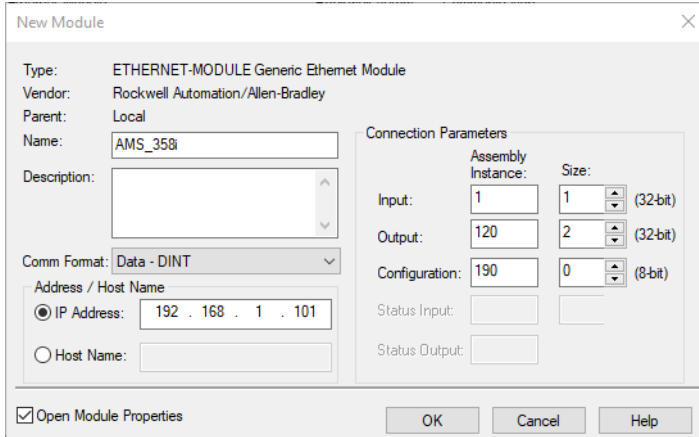

Figure 9.6: Configuration example 1 - RSLogix 5000 up to software version V19.xx

In this configuration, the default settings of the AMS 358/ are applied.

Input assembly 1 and output assembly 120 are active.

Configuration assembly 190 is not active.

9.9.2 Example 2 - RSLogix 5000 up to software version V19.xx

Configuration of a generic module with the use of the configuration assembly

The screenshot shows the 'New Module' dialog box with the following configuration details:

- Type:** ETHERNET-MODULE Generic Ethernet Module
- Vendor:** Rockwell Automation/Allen-Bradley
- Parent:** Local
- Name:** AMS_358i
- Description:** (Empty text area)
- Comm Format:** Data - DINT
- Address / Host Name:**
 - IP Address: 192 . 168 . 1 . 101
 - Host Name: (Empty text field)
- Connection Parameters:**

	Assembly Instance:	Size:
Input:	1	1 (32-bit)
Output:	120	2 (32-bit)
Configuration:	190	102 (8-bit)
Status Input:		
Status Output:		

At the bottom of the dialog, there is a checkbox for 'Open Module Properties' (checked), and 'OK', 'Cancel', and 'Help' buttons.

Figure 9.7: Configuration example 2 - RSLogix 5000 up to software version V19.xx

In this configuration, the default settings of the AMS 358*i* are applied.

Input assembly 1 and output assembly 120 are active.

Configuration assembly 190 is also active.



Attention!

*For the configuration assembly, the generic module reserves memory space equal only to the length of the entered 102 bytes. All bytes (parameters) are preset to 0 (zero). In the first moment, there are, thus, no default parameters stored for the AMS358*i* in the control. The parameters of all 102 bytes must be copied from the EDS file or manually transferred to the configured configuration assembly 190.*

9.9.3 Example 3 - RSLogix 5000 for software versions V20.00 and higher

The RS Logix 5000 takes over all default parameters of configuration assembly 190 from the EDS files.

Other assemblies present in the EDS file can be configured via the "Module Definition".

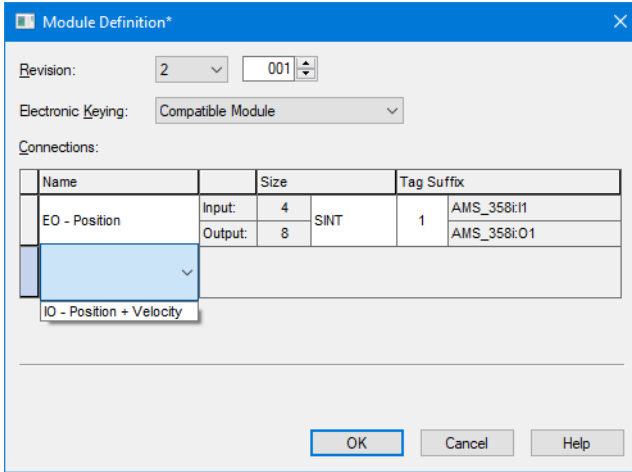

Figure 9.8: Configuration example 3 - RSLogix 5000 for software versions V20.00 and higher

The RSLogix does, however, only permit the use of one input assembly and/or one output assembly and/or one configuration assembly.

Multiple assemblies of type input or output or configuration are not possible.

9.10 EDS file - detailed description



Note!

In the following tables, all attributes marked in the Access column with Get in the individual objects are to be understood as inputs of the control. Attributes marked in the Access column with Set represent outputs or parameters.

9.10.1 Class 4 Assembly

9.10.1.1 Position value

Path			Designation	Size in bit	Data type	Default (dec)	Min. (dec)	Max. (dec)	Access
Cl.	Inst.	Attr.							
4	1	3	Position	32	DINT	0	-2147483648	+2147483648	Get

Instance 1, attribute 3

Input assembly: length 4 bytes

Assembly to read out the position value. According to the definition from the ODVA, the assembly with instance 1 is a mandatory assembly in the encoder profile.

Inst.	Byte	Bit 7	Bit 6	Bit 5	Bit 4	Bit 3	Bit 2	Bit 1	Bit 0
1	0	Position value (low byte)							
	1	Position value							
	2	Position value							
	3	Position value (high byte)							



Note!

Negative values are shown in two's complement.

9.10.1.2 Position value + status

Path			Designation	Size in bit	Data type	Default (dec)	Min. (dec)	Max. (dec)	Access
Cl.	Inst.	Attr.							
4	100	3	Position value	32	DINT	-	-21474836480	+2147483648	Get
			Status	8	Byte	-	0	31	Get
			Alarm warning	8	Byte	-	0	31	Get
			Reserve	16	DINT	0	-	-	Get

Instance 100, attribute 3

Input assembly: length 8 bytes

Leuze-specific assembly

Byte 0 - Byte 3: position value

Byte 4: AMS 358/status

Byte 5: AMS 358/alarms and warnings

Byte 6- Byte 7: reserve

Inst.	Byte	Bit 7	Bit 6	Bit 5	Bit 4	Bit 3	Bit 2	Bit 1	Bit 0	
100	0	Position value (low byte)								
	1	Position value								
	2	Position value								
	3	Position value (high byte)								
	4	0	0	0	Preset toggle	Preset status 1 = ON 0 = OFF	I/O state 2 1 = ON 0 = OFF	I/O state 1 1 = ON 0 = OFF	Laser diode ON / OFF 1 = ON 0 = OFF	
	5	0	0	0	ATT 1 = ON 0 = OFF	LSR 1 = ON 0 = OFF	TMP 1 = ON 0 = OFF	PLB 1 = ON 0 = OFF	ERR 1 = ON 0 = OFF	
	6	0	0	0	0	0	0	0	0	
	7	0	0	0	0	0	0	0	0	



Note!

Negative values are shown in two's complement.

9.10.1.3 Position value + velocity

Cl.	Inst.	Attr.	Designation	Size in bit	Data type	Default (dec)	Min. (dec)	Max. (dec)	Access
4	3	3	Position value	32	DINT	0	-2147483648	2147483647	Get
			Velocity value	32	DINT	0	-999,999	+999,999	Get

Instance 3, attribute 3

Input assembly: length 8 bytes

Assembly to read out the position and velocity value. The assembly with instance 3 complies with the definition of the ODVA encoder profile.

Byte 0 - Byte 3: position value

Byte 4 - Byte 7: velocity value

Inst.	Byte	Bit 7	Bit 6	Bit 5	Bit 4	Bit 3	Bit 2	Bit 1	Bit 0	
003	0	Position value (low byte)								
	1	Position value								
	2	Position value								
	3	Position value (high byte)								
	4	Velocity value (low byte)								
	5	Velocity value								
	6	Velocity value								
	7	Velocity value (high byte)								

9.10.1.4 Velocity value + state

Cl.	Path		Designation	Size in bit	Data type	Default (dec)	Min. (dec)	Max. (dec)	Access
	Inst.	Attr.							
4	101	3	Velocity value	32	DINT	-	-999,999	+999,999	Get
			Status	8	Byte	-	0	63	Get
			Alarm warning	8	Byte	-	0	31	Get
			Reserve	16	DINT	0	-	-	Get

Instance 101, attribute 3

Input assembly: length 8 bytes

Leuze-specific assembly

Byte 0 - Byte 3: velocity value

Byte 4: AMS 358/velocity status

Byte 5: AMS 358/alarms and warnings

Byte 6- Byte 7: reserve

Inst.	Byte	Bit 7	Bit 6	Bit 5	Bit 4	Bit 3	Bit 2	Bit 1	Bit 0
100	0	Velocity value (low byte)							
	1	Velocity value							
	2	Velocity value							
	3	Velocity value (high byte)							
	4	0	0	Direction of movement 0 = Pos. 1 = Neg.	Movement status 1 = Mov. 0 = No mov.	Velocity limit value 4 status 1 = Exceeded 0 = Observed	Velocity limit value 3 status 1 = Exceeded 0 = Observed	Velocity limit value 2 status 1 = Exceeded 0 = Observed	Velocity limit value 1 status 1 = Exceeded 0 = Observed
	5	0	0	0	ATT 1 = ON 0 = OFF	LSR 1 = ON 0 = OFF	TMP 1 = ON 0 = OFF	PLB 1 = ON 0 = OFF	ERR 1 = ON 0 = OFF
	6	0	0	0	0	0	0	0	0
	7	0	0	0	0	0	0	0	0

**Note!**

Negative values are shown in two's complement.

9.10.1.5 Preset value + control

Cl.	Path		Designation	Size in bit	Data type	Default (dec)	Min. (dec)	Max. (dec)	Access
	Inst.	Atr.							
4	120	3	Preset value	32	DINT	-	-	+2147483648	Set
			Preset control	8	Byte	-	0	3	Set
			Reserve	24	DINT	0	-	-	Get

Instance 120, attribute 3

Output assembly: length 8 bytes

Leuze-specific assembly

Byte 0 - Byte 3: preset value

Byte 4: preset control

Byte 5- Byte 7: reserve

Inst.	Byte	Bit 7	Bit 6	Bit 5	Bit 4	Bit 3	Bit 2	Bit 1	Bit 0	
120	0	Preset value (low byte)								
	1	Preset value								
	2	Preset value								
	3	Preset value (high byte)								
	4	0	0	0	0	0	0	0	Preset reset 1 = ON 0 = OFF	Preset teach 1 = ON 0 = OFF
	5	0	0	0	0	0	0	0	0	0
	6	0	0	0	0	0	0	0	0	0
	7	0	0	0	0	0	0	0	0	0



Note!

Negative values are shown in two's complement.

9.10.1.6 Configuration assembly

The configuration assembly is stored in class 4, instance 190.

The length ("size") of the configuration assembly is 102 (see table below byte 0 ... byte 101)

The configuration assembly is completely preset to the values 0 (zero) when transferred to the control.

The entries named in the "Default" column must always be manually transferred to the control if the configuration assembly is used. Automatic transfer of the default settings is not possible.

All other, system-specific parameters, set by the respective programmer, must also be transferred to the configuration assembly.



Note!

Strictly speaking, offset values, preset values and their actuation are not permanent parameters because in some cases they need to be changed depending on the system state. Preset and offset values are therefore not stored in the configuration assembly.

It is essential to make sure that parameters which are set (explicitly) in the AMS 358i via the control (set attribute single Class xx instance xx attribute xx) are also transferred to the configuration assembly.

Only parameters that are also entered in the configuration assembly can be taken into consideration in all operating situations of the AMS 358i. Parameters that are set by means of explicit calls, but not entered in the configuration assembly may therefore only have a temporary effect. The next time the configuration assembly is automatically downloaded to the AMS 358i, these explicitly transferred parameters are overwritten again.

Byte	Cross reference address class/instance/attribute	Function	Bit assignment (default)							Default (hex)	
			7	6	5	4	3	2	1		0
0	35 / 1 / 12	Direction Counting	--	--	--	--	--	--	--	00	
1	35 / 1 / 15	Position format Low byte	0	0	0	0	0	0	1	1	03
2		Position format High byte	0	0	1	0	0	0	1	0	22
3	35 / 1 / 25	Velocity format Low byte	0	0	0	1	0	0	0	0	10
4		Velocity format High byte	0	0	0	0	1	0	0	0	08
5	35 / 1 / 26	Velocity free resolution Low byte	1	1	1	0	1	0	0	0	E8
6		Velocity free resolution	0	0	0	0	0	0	1	1	03
7		Velocity free resolution	0	0	0	0	0	0	0	0	00
8		Velocity free resolution High byte	0	0	0	0	0	0	0	0	00
9	35 / 1 / 107	Position free resolution Low byte	1	1	1	0	1	0	0	0	E8
10		Position free resolution High byte	0	0	0	0	0	0	1	1	03
11	100 / 1 / 1	Language selection	--	--	--	--	--	--	0	0	00
12	100 / 1 / 2	Password protection	--	--	--	--	--	--	--	0	00
13	100 / 1 / 3	Password Low byte	0	0	0	0	0	0	0	0	00
14		Password High byte	0	0	0	0	0	0	0	0	00
15	100 / 1 / 4	Display illumination	--	--	--	--	--	--	--	0	00
16	100 / 1 / 5	Display contrast	--	--	--	--	--	--	0	1	01
17	100 / 1 / 6	Extended heating control	--	--	--	--	--	--	--	0	00
18		Reserved	0	0	0	0	0	0	0	0	00
19		Reserved	0	0	0	0	0	0	0	0	00
20		Reserved	0	0	0	0	0	0	0	0	00

Byte	Cross reference address/instance/attribute	Function	Bit assignment (default)								Default (hex)
			7	6	5	4	3	2	1	0	
21	103 / 1 / 1	Function of I/O (input or output)	--	--	--	--	--	--	--	1	01
22	103 / 1 / 2	Activation (high-active/low-active)	--	--	--	--	--	--	--	0	00
23	103 / 1 / 3	Output function Low byte	1	1	0	0	0	0	--	--	C0
24		Output function High byte	--	--	--	--	--	--	--	0	00
25	103 / 1 / 4	Input function	--	--	--	--	--	--	0	0	00
26	103 / 2 / 1	Function of I/O (input or output)	--	--	--	--	--	--	--	1	01
27	103 / 2 / 2	Activation (high-active/low-active)	--	--	--	--	--	--	--	0	00
28	103 / 2 / 3	Output function Low byte	0	0	1	1	1	0	0	0	38
29		Output function High byte	0	0	0	0	0	0	0	0	00
30	103 / 2 / 4	Input function	--	--	--	--	--	--	0	0	00
31	104 / 1 / 1	Position value in the case of failure	--	--	--	--	--	--	--	1	01
32	104 / 1 / 2	Suppress PLB status (position error)	--	--	--	--	--	--	--	1	01
33	104 / 1 / 3	Error delay (position error)	--	--	--	--	--	--	--	1	01
34	104 / 1 / 4	Position error delay time Low byte	0	1	1	0	0	1	0	0	64
35		Position error delay time High byte	0	0	0	0	0	0	0	0	00
36	104 / 1 / 5	Velocity value in the case of failure	--	--	--	--	--	--	--	1	01
37	104 / 1 / 6	Suppress status (velocity error)	--	--	--	--	--	--	--	1	01
38	104 / 1 / 7	Error delay (velocity error)	--	--	--	--	--	--	--	1	01
39	104 / 1 / 8	Velocity error delay time Low byte	1	1	0	0	1	0	0	0	C8
40		Velocity error delay time High byte	0	0	0	0	0	0	0	0	00
41	105 / 1 / 1	Activation of velocity monitoring	--	--	--	--	--	--	--	0	00
42	105 / 1 / 2	Switching type limit value overshoot/undershoot	--	--	--	--	--	--	--	0	00
43	105 / 1 / 3	Direction selection direction-independent/direction-dependent	--	--	--	--	--	--	--	0	00
44	105 / 1 / 4	Velocity limit value Low byte	0	0	0	0	0	0	0	0	00
45		Velocity limit value High byte	0	0	0	0	0	0	0	0	00
46	105 / 1 / 5	Velocity hysteresis Low byte	0	1	1	0	0	1	0	0	64
47		Velocity hysteresis High byte	0	0	0	0	0	0	0	0	00
48	105 / 1 / 6	Limit value range start Low byte	0	0	0	0	0	0	0	0	00
49		Limit value range start	0	0	0	0	0	0	0	0	00
50		Limit value range start	0	0	0	0	0	0	0	0	00
51		Limit value range start High byte	0	0	0	0	0	0	0	0	00
52	105 / 1 / 7	Limit value range end Low byte	0	0	0	0	0	0	0	0	00
53		Limit value range end	0	0	0	0	0	0	0	0	00
54		Limit value range end	0	0	0	0	0	0	0	0	00
55		Limit value range end High byte	0	0	0	0	0	0	0	0	00
56	105 / 2 / 1	Activation of velocity monitoring	--	--	--	--	--	--	--	0	00
57	105 / 2 / 2	Switching type limit value overshoot/undershoot	--	--	--	--	--	--	--	0	00
58	105 / 2 / 3	Direction selection direction-independent/direction-dependent	--	--	--	--	--	--	--	0	00
59	105 / 2 / 4	Velocity limit value Low byte	0	0	0	0	0	0	0	0	00
60		Velocity limit value High byte	0	0	0	0	0	0	0	0	00
61	105 / 2 / 5	Velocity hysteresis Low byte	0	1	1	0	0	1	0	0	64
62		Velocity hysteresis High byte	0	0	0	0	0	0	0	0	00
63	105 / 2 / 6	Limit value range start Low byte	0	0	0	0	0	0	0	0	00
64		Limit value range start	0	0	0	0	0	0	0	0	00
65		Limit value range start	0	0	0	0	0	0	0	0	00
66		Limit value range start High byte	0	0	0	0	0	0	0	0	00
67	105 / 2 / 7	Limit value range end Low byte	0	0	0	0	0	0	0	0	00

Byte	Cross reference address class/instance/attribute	Function	Bit assignment (default)							Default (hex)	
			7	6	5	4	3	2	1		0
68		Limit value range end	0	0	0	0	0	0	0	0	00
69		Limit value range end	0	0	0	0	0	0	0	0	00
70		Limit value range end High byte	0	0	0	0	0	0	0	0	00
71	105 / 3 / 1	Activation of velocity monitoring	--	--	--	--	--	--	--	0	00
72	105 / 3 / 2	Switching type limit value overshoot/undershoot	--	--	--	--	--	--	--	0	00
73	105 / 3 / 3	Direction selection direction-independent/direction-dependent	--	--	--	--	--	--	--	0	00
74	105 / 3 / 4	Velocity limit value Low byte	0	0	0	0	0	0	0	0	00
75		Velocity limit value High byte	0	0	0	0	0	0	0	0	00
76	105 / 3 / 5	Velocity hysteresis Low byte	0	1	1	0	0	1	0	0	64
77		Velocity hysteresis High byte	0	0	0	0	0	0	0	0	00
78	105 / 3 / 6	Limit value range start Low byte	0	0	0	0	0	0	0	0	00
79		Limit value range start	0	0	0	0	0	0	0	0	00
80		Limit value range start	0	0	0	0	0	0	0	0	00
81		Limit value range start High byte	0	0	0	0	0	0	0	0	00
82	105 / 3 / 7	Limit value range end Low byte	0	0	0	0	0	0	0	0	00
83		Limit value range end	0	0	0	0	0	0	0	0	00
84		Limit value range end	0	0	0	0	0	0	0	0	00
85		Limit value range end High byte	0	0	0	0	0	0	0	0	00
86	105 / 4 / 1	Activation of velocity monitoring	--	--	--	--	--	--	--	0	00
87	105 / 4 / 2	Switching type limit value overshoot/undershoot	--	--	--	--	--	--	--	0	00
88	105 / 4 / 3	Direction selection direction-independent/direction-dependent	--	--	--	--	--	--	--	0	00
89	105 / 4 / 4	Velocity limit value Low byte	0	0	0	0	0	0	0	0	00
90		Velocity limit value High byte	0	0	0	0	0	0	0	0	00
91	105 / 4 / 5	Velocity hysteresis Low byte	0	1	1	0	0	1	0	0	64
92		Velocity hysteresis High byte	0	0	0	0	0	0	0	0	00
93	105 / 4 / 6	Limit value range start Low byte	0	0	0	0	0	0	0	0	00
94		Limit value range start	0	0	0	0	0	0	0	0	00
95		Limit value range start	0	0	0	0	0	0	0	0	00
96		Limit value range start High byte	0	0	0	0	0	0	0	0	00
97	105 / 4 / 7	Limit value range end Low byte	0	0	0	0	0	0	0	0	00
98		Limit value range end	0	0	0	0	0	0	0	0	00
99		Limit value range end	0	0	0	0	0	0	0	0	00
100		Limit value range end High byte	0	0	0	0	0	0	0	0	00
101		Reserved	0	0	0	0	0	0	0	0	00



Attention!

The formats for the position value and for the velocity value are defined in byte 1 to 4. The formats for velocity and position value must always be the same.

Example:

Position value format metric = Velocity format value metric

Differing formats, e.g. position value metric and velocity value inch, are not allowed.

9.10.2 Class 1 Identity object

Object class 1 = 01_H

Service:

- Get_Attribute_Single

Cl.	Path		Designation	Size in bit	Data type	Default (dec)	Min. (dec)	Max. (dec)	Access
	Inst.	Attr.							
1	1	1	Vendor ID	16	UINT	524	-	-	Get
		2	Device type	16	UINT	34	-	-	Get
		3	Product Code	16	UINT	2	-	-	Get
		4	Revision (Major, Minor)	16	Struct{ USINT major, USINT minor};	Major = 1, Minor = 1	Major = 1, Minor = 1	Major = 127, Minor = 999	Get
		5	Status	16	WORD	See CIP specification (5-2.2.1.5 status)			Get
		6	Serial Number	32	UDINT	Manufacturer specific			Get
		7	Product Name	(max. 32) x 8	SHORT_STRING	"AMS 358i"			Get
		8	State	8	USINT	Default: 0			Get
		9	Configuration consistency value	16	UINT	Default 0 (limited support)			Get

In the event of a device exchange in the system, the major revision number should **not** be monitored. The major revision number describes the firmware version of the AMS 358*i*/software within the EDS file/object 1. This may have changed during a possible device exchange. The scanner would otherwise output an error message after a device is changed.

9.10.2.1 Vendor ID

The Vendor ID assigned by ODVA for Leuze electronic GmbH + Co. KG is 524_D.

9.10.2.2 Device type

The AMS 358*i* is defined by Leuze as an encoder. According to ODVA, the AMS 358*i* is assigned number 34_D = 22_H.

9.10.2.3 Product Code

The product code is an ID assigned by Leuze that has no further impact on other objects.

9.10.2.4 Revision

Version number of the identity object.

9.10.2.5 Status

Basic and higher-level monitoring of the device, network and configuration. The entries are described by the scanner.

Bit 7	Bit 6	Bit 5	Bit 4	Bit 3	Bit 2	Bit 1	Bit 0
Ext. device state				Reserved	Configured	Reserved	Owned
Bit 15	Bit 14	Bit 13	Bit 12	Bit 11	Bit 10	Bit 9	Bit 8
Reserved				Major unrecoverable fault	Major recoverable fault	Major unrecoverable fault	Major recoverable fault

9.10.2.6 Serial number

For use in Ethernet, the serial number receives a serial number converted according to CIP. CIP describes a special format for the serial number. After conversion to a CIP code, the serial number is, as before, unique, but no longer corresponds in its resolution to the serial number on the name plate.

9.10.2.7 Product Name

This attribute contains a short designation of the product. Devices with the same product code may have different "product names".

9.10.2.8 State

This attribute contains information on the current status of the AMS358i.

9.10.2.9 Configuration consistency value

If a parameter is changed, an entry can be made in this attribute. The function is not supported by the AMS 358*i*. The default entry 0 (zero) does not change.

9.10.2.10 Heartbeat interval

The attribute sets a time interval in which a "heartbeat message" is sent by the AMS 358*i*. The value is specified in seconds.

9.10.3 Class 35 Position sensor object

Object class 35 = 23_H

Service:

- Get_Attribute_Single
- Set_Attribute_Single

Cl.	Path		Designation	Size in bit	Data type	Default (dec)	Min. (dec)	Max. (dec)	Access
	Inst.	Attr.							
35	1	10	Position value	32	DINT	0	- 2147483648	2147483647	Get
		11	Sensor type	16	UINT	8	-	-	Get
		12	Direction Counting	8	BYTE	0	0	1	Set
		15	Position format	16	ENGUNIT	8707	See below		Set
		24	Velocity value	32	DINT	0	-999,999	999,999	Get
		25	Velocity format	16	ENGUNIT	2064	See below		Set
		26	Velocity resolution	32	UDINT	1000	1	50,000	Set
		41	Operating status	8	BYTE	0	See below		Get
		44	Alarms	16	WORD	0	See below		Get
		45	Supported alarms	16	WORD	See below			Get
		46	Alarm flag	8	BYTE	0	0	1	Get
		47	Warnings	16	WORD	0	See below		Get
		48	Supported warnings	16	WORD	See below			Get
		49	Warning flag	8	BYTE	0	0	1	Get
		50	Operating time	32	UDINT	0	0	4294967295	Get
		100	Preset value	32	DINT	0	-999,999	999,999	Set
		101	Preset teach	8	BYTE	0	0	1	Set
		102	Preset status	8	BYTE	0	0	1	Get
		103	Preset toggle	8	BYTE	0	0	1	Get
		104	Preset reset	8	BYTE	0	0	1	Set
		105	Direction of movement	8	BYTE	0	0	1	Get
		106	Movement status	8	BYTE	0	0	1	Get
		107	Free resolution	16	UINT	5	5	50,000	Set
		108	Offset value	32	DINT	0	-999,999	999,999	Set
		109	Laser status	8	BYTE	0	0	1	Get
		110	Laser control	8	BYTE	0	0	1	Set

In the CIP network specifications, the function of object class 35 (23_H) is defined as a "position sensor object". The position sensor object describes the functions of an absolute measuring encoder. As defined in the CIP specification, the attributes with address 1 to 99 are functionally predetermined. From this address range, the AMS 358/uses only attributes that are functionally mapped in the AMS. The address range ≥ 100 is manufacturer-specific.

9.10.3.1 Position Value

Attribute 10

Reading out position value.

Attr.	Byte	Bit 7	Bit 6	Bit 5	Bit 4	Bit 3	Bit 2	Bit 1	Bit 0
10	0	Position value (low byte)							
	1	Position value							
	2	Position value							
	3	Position value (high byte)							

**Note!**

Negative values are shown in two's complement.

9.10.3.2 Position sensor type

Attribute 11

Specifies the encoder with the CIP-defined identifier 8_a as an absolute measuring linear encoder.

9.10.3.3 Direction Counting

Attribute 12

Defines whether the measured distance value increases as the distance increases (positive counting direction) or as the distance decreases (negative counting direction).

0 = Positive counting direction

1 = Negative counting direction

9.10.3.4 Position format

Attribute 15

Configures the position format as well as the resolution. The EDS file provides the following parameters:

Dec. value	Hex. Value	Unit	Format
8706	0x22 02	Centimeter [cm]	metric
8707	0x22 03	Millimeter [mm]	
8708	0x22 04	Micrometer [μ m]	
2048	0x08 00	Free resolution [mm]	
2049	0x08 01	Tenth of millimeter [mm/10]	
2050	0x08 02	Hundredth of millimeter [mm/100]	
2051	0x08 03	Hundredth of inch [in/100]	Inch
2052	0x08 04	Free resolution [in/100]	

**Note!**

If the position format is changed from metric to inch, the velocity format is internally changed automatically to hundredths of inch per second. If the position format is changed from inch to metric, the velocity format is internally changed automatically to millimeters per second.

9.10.3.5 Velocity value

Attribute 24

Reading out velocity value.

Attr.	Byte	Bit 7	Bit 6	Bit 5	Bit 4	Bit 3	Bit 2	Bit 1	Bit 0
24	0	Velocity value (low byte)							
	1	Velocity value							
	2	Velocity value							
	3	Velocity value (high byte)							



Note!

Negative values are shown in two's complement.

9.10.3.6 Velocity format

Attribute 25

Configures the velocity format as well as the resolution. The EDS file provides the following parameters:

Dec. value	Hex. Value	Unit	Format
11008	0x2B 00	Meter per second [m/s]	metric
11009	0x2B 01	Centimeter per second [cm/s]	
2064	0x08 10	Millimeter per second [mm/s]	
2065	0x08 11	Decimeter per second [dm/s]	
2066	0x08 12	Hundredth of inch per second [(in/100)/s]	Inch
2067	0x08 13	Meter per minute [m/min]	metric
2068	0x08 14	Free resolution [(mm/100)/s]	
2069	0x08 15	Free resolution [(in/1000)/s]	Inch



Note!

If the velocity format is changed from metric to inch, the position format is internally changed automatically to hundredths of inch. If the velocity format is changed from inch to metric, the position format is internally changed automatically to millimeters.

9.10.3.7 Velocity free resolution

Attribute 26

The free resolution refers to parameters 2068 and 2069 in attribute 25 (Velocity format). The entry is made in mm/100 s for parameter 2068 and in inch/1000 s for parameter 2069.

9.10.3.8 Operating status - Direction counting

Attribute 41

Bit 7	Bit 6	Bit 5	Bit 4	Bit 3	Bit 2	Bit 1	Bit 0
Vendor spec.			Reserved			Scaling	Direction

Attribute 41 is the response of the AMS 358/ to the counting direction configured in attribute 12.

The counting direction is output in bit 0.

0 = Positive counting direction

1 = Negative counting direction

Bits 1 to 7 are irrelevant and have the status 0.

9.10.3.9 Alarms

Attribute 44

Bit 7	Bit 6	Bit 5	Bit 4	Bit 3	Bit 2	Bit 1	Bit 0
Reserved						ERR	PLB
Bit 15	Bit 14	Bit 13	Bit 12	Bit 11	Bit 10	Bit 9	Bit 8
Vendor spec.				Reserved			

The PLB and ERR status messages generated by the AMS 358/ are entered in bit 0 and bit 1.

The alarms entered here lead to incorrect measurement values at the AMS 358/. The CIP specification makes a distinction between alarms and warnings.

The following applies for PLB and ERR:

0 = No alarm

1 = Alarm

9.10.3.10 Supported alarm

Attribute 45

Attribute 45 indicates which alarms specified by the position sensor object are supported by the AMS 358/.

Bit 7	Bit 6	Bit 5	Bit 4	Bit 3	Bit 2	Bit 1	Bit 0
Reserved						1	1
Bit 15	Bit 14	Bit 13	Bit 12	Bit 11	Bit 10	Bit 9	Bit 8
Vendor spec.				Reserved			

Bit 0 = 1; PLB alarm is supported by the AMS 358/.

Bit 1 = 1; ERR alarm is supported by the AMS 358/.

Bit 2 to bit 15 = 0

Bit 13 = 1 (VME; velocity / velocity)

9.10.3.11 Alarm flag

Attribute 46

The attribute evaluates the alarms supported in attribute 45, in an OR function. (collective alarm)

9.10.3.12 Warnings

Attribute 47

According to the CIP specification, warning messages are messages that signal exceedance of internal limit values, but do not lead to incorrect measurement values.

As warnings, the AMS 358*i* enters the ATT, LSR and TMP status messages. A range for device-specific data is reserved for this purpose in the CIP specification (bits 13 to 15).

Bit 7	Bit 6	Bit 5	Bit 4	Bit 3	Bit 2	Bit 1	Bit 0
-	-	-	-	-	-	-	-
Bit 15	Bit 14	Bit 13	Bit 12	Bit 11	Bit 10	Bit 9	Bit 8
ATT	LSR	TMP	-	-	-	-	-

9.10.3.13 Supported warnings

Attribute 48

Attribute 48 indicates which warnings specified by the position sensor object are supported by the AMS 358*i*.

Bit 7	Bit 6	Bit 5	Bit 4	Bit 3	Bit 2	Bit 1	Bit 0
-	-	-	-	-	-	-	-
Bit 15	Bit 14	Bit 13	Bit 12	Bit 11	Bit 10	Bit 9	Bit 8
1	1	1	-	-	-	-	-

Bit 13 = 1; TMP warning is supported by the AMS 358*i*

Bit 14 = 1; LSR warning is supported by the AMS 358*i*

Bit 15 = 1; ATT warning is supported by the AMS 358*i*

Bit 0 to bit 12 = 0

9.10.3.14 Warning flag

Attribute 49

The attribute evaluates the warnings supported in attribute 48, in an OR function (collective warning).

9.10.3.15 Operating time

Attribute 50

The value is incremented in 1/10 hours for as long as the AMS 358/i is connected to voltage.
The value cannot be reset.

9.10.3.16 Preset value

Attribute 100

The attribute enables the current position value to be set to a desired position value.

Attr.	Byte	Bit 7	Bit 6	Bit 5	Bit 4	Bit 3	Bit 2	Bit 1	Bit 0
100	0	Preset value (low byte)							
	1	Preset value							
	2	Preset value							
	3	Preset value (high byte)							

9.10.3.17 Preset teach

Attribute 101

The attribute activates the value configured in attribute 100.

1 = Preset teach



Note!

As a result

- attribute 103 is toggled,
- attribute 102 is set.

9.10.3.18 Preset status

Attribute 102

The attribute indicates whether the preset function is activated.

1 = Preset active

0 = Preset inactive

9.10.3.19 Preset toggle

Attribute 103

The attribute is toggled after activation of the preset value.



Note!

Activation of the preset value via attribute 101.

9.10.3.20 Preset reset

Attribute 104

The attribute deletes the set preset value. The preset status (attribute 102) is set to inactive.

1 = Delete preset value.

9.10.3.21 Direction of movement

Attribute 105

At a velocity > 100 mm/s, the attribute indicates the direction of movement.

0 = Positive direction of movement

1 = Negative direction of movement

Definition of the direction of movement depends on class 35, instance 1, attribute 12:

- Counting direction positive:
Measurement values **increase** when the reflector moves away from the AMS 358/. In this case, the positive direction of movement is 0 in attribute 105.
- Counting direction negative:
Measurement values **decrease** when the reflector moves away from the AMS 358/. In this case, the positive direction of movement is 1 in attribute 105.

9.10.3.22 Movement status

Attribute 106

The attribute indicates whether, based on the value, a movement > 100 mm/s is registered.

0 = |curr. velocity| < 100 mm/s

1 = |curr. velocity| > 100 mm/s

9.10.3.23 Free resolution

Attribute 107

The free resolution refers to parameters 2048 and 2052 in attribute 15.

The entry is made in mm/1000 for parameter 2048 and in inch/100,000 for parameter 2052.

Example:

For a free resolution of e.g. 0.875 mm, the value "875" must then be entered for parameter 2048.

9.10.3.24 Offset

Attribute 108

Measurement value at the interface = measured distance + offset.

The attribute sets an offset relative to the measured value in the AMS 358/. The offset is immediately effective after the instruction "set attribute single class1 instance1 attribut108".

Attr.	Byte	Bit 7	Bit 6	Bit 5	Bit 4	Bit 3	Bit 2	Bit 1	Bit 0
108	0	Offset value (low byte)							
	1	Offset value							
	2	Offset value							
	3	Offset value (high byte)							

If the preset value is activated, this has priority over the offset. Preset and offset are not offset against each other.

9.10.3.25 Laser diode status

Attribute 109

The attribute signals the status of the laser diode.

0 = Laser diode OFF

1 = Laser diode ON

9.10.3.26 Laser diode control

Attribute 110

This attribute is used to switch the laser on and off.

1 = Laser diode ON

0 = Laser diode OFF

9.10.4 Class 100 Display configuration

Object class 100 = 64_H

Service:

- Get_Attribute_Single
- Set_Attribute_Single

Cl.	Path		Designation	Size in bit	Data type	Default (dec)	Min. (dec)	Max. (dec)	Access
	Inst.	Attr.							
100	1	1	Language selection	8	BYTE	0	0	4	Set
		2	Password protection	8	BYTE	0	0	1	Set
		3	Password	16	UINT	0	0	9,999	Set
		4	Illumination	8	BYTE	0	0	1	Set
		5	Contrast	8	BYTE	1	0	2	Set
		6	Extended heating control	8	BYTE	0	0	1	Set

9.10.4.1 Language selection

Attribute 1

The attribute is used to configure the display language.

The table below provides information on the languages available.

Language	Value
English	0
German	1
Italian	2
Spanish	3
French	4

9.10.4.2 Password protection

Attribute 2

The attribute activates password protection.

- 1 = Password protection active
- 0 = Password protection not active

9.10.4.3 Password

Attribute 3

The attribute specifies the password. The password protection attribute (attribute 2) must be activated. Value range for the password: 0000 - 9999.

The master password **2301** is used to activate parameter enable via the display/panel.

9.10.4.4 Illumination

This attribute is used to set whether the display illumination is to be switched off 10 minutes after a button was last pressed, or whether the display illumination is always on.

- 0 = Display illumination switches off 10 minutes after a button was last pressed
- 1 = Display illumination is always on

9.10.4.5 Contrast

The display contrast can change under extreme ambient temperatures. This attribute adjusts the display illumination.

Value	Contrast
0	Weak
1	Medium
2	Strong

9.10.4.6 Extended heating control

This attribute is used to activate extended heating control.

The extended heating control range of the internal device heating can help to prevent condensation from forming on the optics of the AMS 358/. If the parameter is set, the internal heating of the AMS 358/ is switched on at high ambient temperatures (30°C).

In the case of extremely large and rapid changes in temperature and air humidity, the capacity of the internal heating may not be sufficient to prevent the formation of condensation.

On Off

0 = Switch-on/switch-off temperature for the internal 10°C (50°F) 15°C (59°F)
heating:

1 = Switch-on/switch-off temperature for the internal 30°C (86°F) 35°C (95°F)
heating:

9.10.5 Class 103 Switching inputs / outputs

Class 103, instance 1 describes I/O 1 (PIN 2/M12 Power)

Class 103, instance 2 describes I/O 2 (PIN 4/M12 Power)

Object class 103 = 67_H

Service:

- Get_Attribute_Single
- Set_Attribute_Single

Cl.	Path		Designation	Size in bit	Data type	Default (dec)	Min. (dec)	Max. (dec)	Access
	Inst.	Attr.							
103	1	1	Function of I/O (input/output)	8	BYTE	1	0	1	Set
		2	Activation (high-active/low-active)	8	BYTE	0	0	1	Set
		3	Output function	16	WORD	192	0	511	Set
		4	Input function	8	BYTE	0	0	3	Set
		5	Status (input/output)	8	BYTE	0	0	1	Get
		6	Output activation	8	BYTE	0	0	1	Set
103	2	1	Function of I/O (input/output)	8	BYTE	1	0	1	Set
		2	Activation (high-active/low-active)	8	BYTE	0	0	1	Set
		3	Output function	16	WORD	56	0	511	Set
		4	Input function	8	BYTE	0	0	3	Set
		5	Status (input/output)	8	BYTE	0	0	1	Get
		6	Output activation	8	BYTE	0	0	1	Set

9.10.5.1 Definition of input/output

Instance 1, attribute 1 (PIN 2/M12 Power)

Instance 2, attribute 1 (PIN 4/M12 Power)

This attribute defines whether the function of PIN 2/PIN 4 at the M12 Power connection is an input or output.

1 = Output

0 = Input

Attribute description for cases where attribute 1 in instance 1 or 2 is selected as a switching input.

9.10.5.2 Activation for inputs

Instance 1, attribute 2 (PIN 2/M12 Power)

Instance 2, attribute 2 (PIN 4/M12 Power)

The switching input of the AMS 358*/i* is edge-triggered.

0 = Switching input reacts to a falling edge (transition from logical 1 to 0)

1 = Switching input reacts to a rising edge (transition from logical 0 to 1)

9.10.5.3 Function assignment of inputs

Instance 1, attribute 4 (PIN 2/M12 Power)

Instance 2, attribute 4 (PIN 4/M12 Power)

Attribute 4 determines which function is to be triggered in the AMS 358*/i* when the input is set.

Bit 7	Bit 6	Bit 5	Bit 4	Bit 3	Bit 2	Bit 1	Bit 0
-	-	-	-	-	-	Laser ON/ OFF	Preset teach

Bit 0 = Preset teach

The switching input reacts to the edge set in attribute 2. The preset value is adopted at the position at which the switching input detects an edge change as defined in attribute 2.

Bit 1 = Laser ON/OFF

The switching input reacts to the edge set in attribute 2. The laser is switched OFF if the switching input detects an edge change as described in attribute 2. If an opposing edge is detected at the switching input, the laser is switched ON again.

9.10.5.4 Input function state

Instance 1, attribute 5 (PIN 2/M12 Power)

Instance 2, attribute 5 (PIN 4/M12 Power)

0 = Input function is not active. Neither Laser ON/OFF nor Preset teach is active.

1 = Input function is active. Laser ON/OFF or Preset teach or both has been activated.

Attribute description for cases where attribute 1 in instance 1 or 2 is selected as a switching output.

9.10.5.5 Activation for outputs

Instance 1, attribute 2 (PIN 2/M12 Power)

Instance 2, attribute 2 (PIN 4/M12 Power)

The attribute defines the level of the output at which the "Output" event occurs.

0 = from logical 1 to logical 0 if the "output" event occurs (see Attribute 3)

1 = from logical 0 to logical 1 if the "output" event occurs (see Attribute 3)

9.10.5.6 Function assignment of hardware outputs

Instance 1, attribute 3 (PIN 2/M12 Power)

Instance 2, attribute 3 (PIN 4/M12 Power)

The attribute defines which event triggers activation of the output. The individual functions are OR-linked.

Bit 7	Bit 6	Bit 5	Bit 4	Bit 3	Bit 2	Bit 1	Bit 0
Hardware (ERR)	Plausibility (PLB)	Laser (LSR)	Temperature (TMP)	Intensity (ATT)	Velocity limit value violated	Reserved	
Reserved							Dynamic output

For instance 1 attribute 3, the default $192_d / 00 C0_h / 0000 0000 1100 0000_b$ is specified. This means that an edge change, as defined in attribute 2, takes place at the output (PIN 2) if the ERR or PLB message occurs.

For instance 2 attribute 3, the default $56_d / 00 38_h / 0000 0000 0011 1000_b$ is specified. This means that an edge change, as defined in attribute 2, takes place at the output (PIN 4) if the LSR or TMP or ATT message occurs.

9.10.5.7 Output function state

Instance 1, attribute 5 (PIN 2/M12 Power)

Instance 2, attribute 5 (PIN 4/M12 Power)

- 0 = Output function is not active. No event from attribute 3 is active.
- 1 = Output function is active. At least one event from attribute 3 is activated.

9.10.5.8 Activation of output (dynamic output)

Instance 1, attribute 6 (PIN 2/M12 Power)

Instance 2, attribute 6 (PIN 4/M12 Power)

With the dynamic output, the hardware outputs (PIN 2/PIN 4) can be set using the control software.

Actuation takes place via bit 8.

- 0 = Dynamic output active
- 1 = The hardware output(s) are set as defined in attribute 2

Dynamic setting of the outputs is performed via 256_d (256 = without taking the status messages bit 7 to bit 2 into consideration).

9.10.6 Class 104 Error handling procedures

Object class 104 = 68_H

Service:

- Get_Attribute_Single
- Set_Attribute_Single

Cl.	Path		Designation	Size in bit	Data type	Default (dec)	Min. (dec)	Max. (dec)	Access
	Inst.	Attr.							
104	1	1	Position value in the case of failure	8	BYTE	1	0	1	Set
		2	Suppress position status	8	BYTE	1	0	1	Set
		3	Error delay (position)	8	BYTE	1	0	1	Set
		4	Error delay time (position)	16	UINT	100	100	1,000	Set
		5	Velocity in the case of failure	8	BYTE	1	0	1	Set
		6	Suppress velocity status	8	BYTE	1	0	1	Set
		7	Error delay (velocity)	8	BYTE	1	0	1	Set
		8	Error delay time (velocity)	16	UINT	100	100	1,000	Set

9.10.6.1 Position value in the case of failure

Attribute 1

The attribute specifies which position is transferred, in the event of an error, after the "Position error delay time" has elapsed.

- 0 = Last valid value
- 1 = Value 0

9.10.6.2 Position status error delay

Attribute 2

The attribute specifies whether the PLB status bit (implausible measurement value) is set immediately or after the "Position error delay time" has elapsed.

- 0 = PLB status bit is set immediately
- 1 = PLB status bit is set after the delay

9.10.6.3 Position error delay

Attribute 3

The attribute specifies whether, in the event of an error, the position value outputs the value of attribute 1 immediately (0 or last valid value) or outputs the last valid position value for the configured error delay time (attribute 4).

- 0 = Error delay deactivated
- 1 = Error delay activated

9.10.6.4 Position error delay time

Attribute 4

Errors which occur are suppressed for the configured time. If no valid position value can be ascertained during the configured time, the last valid position value is output. If the error persists after the time elapses, the value configured in the "Position value in the case of failure" attribute (attribute 1) is output. The error delay time is specified in milliseconds [ms] and must be between 100 and 1000.

9.10.6.5 Velocity in the case of failure

Attribute 5

The attribute specifies which velocity is transferred, in the event of an error, after the "Velocity error delay time" has elapsed.

- 0 = Last valid value
- 1 = Value 0

9.10.6.6 Velocity status error delay

Attribute 6

The attribute specifies whether the PLB status bit (implausible measurement value) is set immediately or after the "Velocity error delay time" has elapsed.

- 0 = PLB status bit is set immediately
- 1 = PLB status bit is set after the delay

9.10.6.7 Velocity error delay

Attribute 7

The attribute specifies whether, in the event of an error, the velocity value outputs the value of attribute 5 immediately (0 or last valid value) or outputs the last valid velocity value for the configured error delay time (attribute 8).

- 0 = Error delay deactivated
- 1 = Error delay activated

9.10.6.8 Velocity error delay time

Attribute 8

Errors which occur are suppressed for the configured time. If no valid velocity value can be ascertained during the configured time, the last valid velocity value is output. If the error persists after the time elapses, the value configured in the "Velocity in the case of failure" attribute (attribute 5) is output. The error delay time is specified in milliseconds [ms] and must be between 200 and 1000.

9.10.7 Class 105 Velocity monitoring

Class 105, instance 1: attributes for velocity limit value 1

Class 105, instance 2: attributes for velocity limit value 2

Class 105, instance 3: attributes for velocity limit value 3

Class 105, instance 4: attributes for velocity limit value 4

Object class 105 = 69_H

Service:

- Get_Attribute_Single
- Set_Attribute_Single

Path			Designation	Size in bit	Data type	Default (dec)	Min. (dec)	Max. (dec)	Access
Cl.	Inst.	Attr.							
105	1	1	Release	8	BYTE	0	0	1	Set
		2	Switching type	8	BYTE	0	0	1	Set
		3	Direction selection	8	BYTE	0	0	1	Set
		4	Velocity limit value	16	UINT	0	0	20,000	Set
		5	Velocity hysteresis	16	UINT	100	0	20,000	Set
		6	Limit value range start	32	DINT	0	-999,999	999,999	Set
		7	Limit value range end	32	DINT	0	-999,999	999,999	Set
		8	Status limit value	8	BYTE	0	0	1	Get
		9	Limit value comparison	8	BYTE	0	0	1	Get
105	2	1	Release	8	BYTE	0	0	1	Set
		2	Switching type	8	BYTE	0	0	1	Set
		3	Direction selection	8	BYTE	0	0	1	Set
		4	Velocity limit value	16	UINT	0	0	20,000	Set
		5	Velocity hysteresis	16	UINT	100	0	20,000	Set
		6	Limit value range start	32	DINT	0	-999,999	999,999	Set
		7	Limit value range end	32	DINT	0	-999,999	999,999	Set
		8	Status limit value	8	BYTE	0	0	1	Get
		9	Limit value comparison	8	BYTE	0	0	1	Get
105	3	1	Release	8	BYTE	0	0	1	Set
		2	Switching type	8	BYTE	0	0	1	Set
		3	Direction selection	8	BYTE	0	0	1	Set
		4	Velocity limit value	16	UINT	0	0	20,000	Set
		5	Velocity hysteresis	16	UINT	100	0	20,000	Set
		6	Limit value range start	32	DINT	0	-999,999	999,999	Set
		7	Limit value range end	32	DINT	0	-999,999	999,999	Set
		8	Status limit value	8	BYTE	0	0	1	Get
		9	Limit value comparison	8	BYTE	0	0	1	Get
105	4	1	Release	8	BYTE	0	0	1	Set
		2	Switching type	8	BYTE	0	0	1	Set
		3	Direction selection	8	BYTE	0	0	1	Set
		4	Velocity limit value	16	UINT	0	0	20,000	Set
		5	Velocity hysteresis	16	UINT	100	0	20,000	Set
		6	Limit value range start	32	DINT	0	-999,999	999,999	Set
		7	Limit value range end	32	DINT	0	-999,999	999,999	Set
		8	Status limit value	8	BYTE	0	0	1	Get
		9	Limit value comparison	8	BYTE	0	0	1	Get

The described attributes each apply to instances 1 - 4

9.10.7.1 Velocity limit value - Release

Attribute 1

The attribute activates the respective velocity monitoring.

0 = Inactive

1 = Active

9.10.7.2 Velocity limit value - Switching type

Attribute 2

The attribute specifies whether the velocity limit value is to be checked for overshooting or undershooting (attribute 3 and 4).

0 = Check for value greater than limit

1 = Check for value less than limit

9.10.7.3 Velocity limit value - Direction selection

Attribute 3

The attribute specifies whether the velocity check is to be performed direction-dependent or direction-independent.

If a direction-dependent limit value check is activated via attribute 2, the values of range start and range end also define the direction. The check is always performed from range start to range end. For example, if the range start is "5500" and the range end is "5000", the direction-dependent check is only performed in the direction from "5500" to "5000". The limit value is not active in the opposite direction.

If the check is independent of direction, the order of range start and range end is irrelevant.

In the case of overshooting or undershooting, the limit value status (attribute 7) and, where applicable, the output are set via class 103, instance 1 or 2, attribute 3 (depending on the selected switching type).

0 = Direction independent

1 = Direction dependent

9.10.7.4 Velocity limit value - Velocity limit value

Attribute 4

The limit value configured in attribute 3 is compared with the measured ACTUAL velocity. The entry is made in mm/s or inch/100s.

9.10.7.5 Velocity limit value - Velocity hysteresis

Attribute 5

Attribute 4 describes the switching hysteresis for the value entered in attribute 3 to prevent signal bouncing. The entry is made in mm/s or inch/100s.

9.10.7.6 Velocity limit value - Limit value range start

Attribute 6

The limit value is monitored beginning at this position. The value is specified in mm or inch/100.

If the values for range start and range end are identical, velocity monitoring is active over the entire traversing range.

9.10.7.7 Velocity limit value - Range end limit value

Attribute 7

The limit value is monitored up to this position. The value is specified in mm or inch/100.

If the values for range start and range end are identical, velocity monitoring is active over the entire traversing range.

9.10.7.8 Velocity limit value - Status limit value

Attribute 8

The attribute signals exceedance of the configured limit values.

0 = Limit values observed

1 = Limit values exceeded

9.10.7.9 Velocity limit value - Limit value comparison

Attribute 9

The attribute indicates whether the respective velocity limit value is compared with the configured limit value.

0 = Comparison not active

1 = Comparison active

10 Diagnostics and troubleshooting

10.1 Service and diagnosis in the display of the AMS 358/i

In the main menu of the AMS 358/i, expanded "Diagnostics" can be called up under the Service heading.

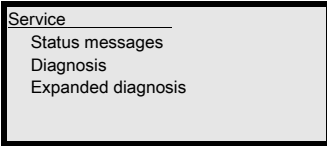

From the Service main menu, press the enter button (↵) to access the underlying menu level. Use the up/down buttons (▲ ▼) to select the corresponding menu item in the selected level; use the enter button (↵) to activate the selection. Return from any sub-level to the next-higher menu item by pressing the ESC button (⏏).

10.1.1 Status messages

The status messages are written in a ring memory with 25 positions. The ring memory is organized according to the FIFO principle. No separate activation is necessary for storing the status messages. Power OFF clears the ring memory.



Basic representation of the status messages

n: Type / No. / 1

Meaning:

n: memory position in the ring memory

Type: type of message:

I = info, W = warning, E = error, F = severe system error.

No: internal error detection

1: frequency of the event (always "1" because no summation occurs)

The status messages within the ring memory are selected with the up/down buttons (▲ ▼). Use the enter button (↵) to call up **detailed information** about the respective status message:

Detailed information about a status message

Type: type of message + internal counter
UID: Leuze-internal coding of the message
ID: description of the message
Info: not currently used

Within the detailed information, press the enter button  again to activate an **action menu** with the following functions:



- Acknowledge message
- Delete message
- Acknowledge all
- Delete all

10.1.2 Diagnosis

The diagnostics function is activated by selecting the Diagnostics menu item. The ESC button  deactivates the diagnostics function and clears the contents of the recordings.

The recorded diagnostic data is displayed in 2 fields. In the upper half of the display, status messages of the AMS and the bar graph are displayed. The lower half contains information used for Leuze-internal evaluation.

IO1	LSR	PLB	
IO2	TMP	ATT	
ERR			
Pos. act.:		-----	
Pos. min.:		-----	
Pos. max.:		-----	

Use the up/down buttons   to scroll in the bottom half between various displays. The contents of the scrollable pages are intended solely for Leuze for internal evaluation.

The diagnostics have no influence on communication with the host interface and can be activated during operation of the AMS 358*i*.

10.1.3 Expanded diagnosis

The Expanded diagnosis menu item is used for Leuze-internal evaluation.

10.2 General causes of errors

The LEDs for PWR and Net are designed as bicolor LEDs. A change in color from red/green and a static/flashing display provide information for further diagnosis.

After power ON, the Power LED and Net LED are tested as follows:

1. LEDs off.
2. LEDs are switched to green for approx. 0.25s.
3. LEDs are switched to red for approx. 0.25s.
4. LEDs off.

This is followed by the status display for the Power LED (see chapter 9.3) and the Net LED.

LINK LED for BUS IN and BUS OUT

A green/yellow multicolor LED below the BUS IN and BUS OUT connectors indicates the EtherNet/IP connection status.



 **Green continuous light**

LINK LED green

- The link exists, the hardware connection to the next connected participant is OK.

 **Flashing yellow**

LINK LED flashes yellow

- Data is exchanged with the connected participants.

10.2.1 Power LED

See also Chapter 8.2.2.

Error	Possible error cause	Measure
PWR LED "OFF"	No supply voltage connected	Check supply voltage.
	Hardware error	Send in device.

Table 10.1: General causes of errors

Error	Possible error cause	Measure
PWR LED "flashes red"	Light beam interruption	Check alignment.
	Plausibility error	Traverse rate >10m/s.
PWR LED "static red"	Hardware error	For error description, see display. It may be necessary to send in the device.

Table 10.1: General causes of errors

10.3 Interface errors

10.3.1 Net LED

Error	Possible error cause	Measure
Net LED "OFF"	Power off on AMS 358/	Check supply voltage.
	no IP address assigned (BootP/DHCP)	Check wiring
	Service operation (parameter enabling activated)	Exiting service operation
Net LED "flashes red"	Time-out in bus communication	AMS 358/ configured in the control.
Net LED "static red"	Double IP address assignment	Check IP addresses.
Net LED "flashes green"	No communication can be established	Check configuration in the control.
	The AMS 358/ is not listed in the scan list of the master	
Net LED "flashes green/red"	The AMS 358i is not assigned to a master	Check configuration in the control.
	No EtherNet/IP communication present	
	Self test during device start	No measures necessary

Table 10.2: Bus error

10.4 Status indicators in the display of the AMS 358/

Display	Possible error cause	Measure
PLB (implausible measurement values)	Laser beam interruption	Laser spot must always be incident on the reflector.
	Laser spot outside of reflector	Traverse rate < 10m/s?
	Measurement range for maximum distance exceeded	Restrict traversing path or select AMS with larger measurement range.
	Velocity greater than 10m/s	Reduce velocity.
	Ambient temperature far outside permissible range (TMP display; PLB)	Select AMS with heating or ensure cooling.
ATT (insufficient received signal level)	Reflector soiled	Clean reflector or glass lens.
	Glass lens of the AMS soiled	
	Performance reduction due to snow, rain, fog, condensing vapor or heavily polluted air (oil mist, dust)	Optimize usage conditions.
	Laser spot only partially on reflector	Check alignment.
TMP (operating temperature outside of specification)	Protective film on reflector	Remove protective film from reflector.
	Ambient temperatures outside specified range	In case of low temperatures, remedy may be an AMS with heating. If temperatures are too high, provide cooling or change mounting location.
LSR Laser diode warning	Laser diode prefailure message	Send in device at next possible opportunity to have laser diode replaced. Have replacement device ready.
ERR Hardware error	Indicates an uncorrectable error in the hardware	Send in device for repair.

Service hotline:

You can find the contact information for the hotline in your country on our website www.leuze.com under "Contact & Support".

Repair service and returns:

Defective devices are repaired at our service centers competently and quickly. We offer you an extensive service packet to keep any system downtimes to a minimum. Our service center requires the following information:

- Your customer number
- Product description or part description
- Serial number and batch number
- Reason for requesting support together with a description

For this purpose, please register the merchandise concerned. Simply register return of the merchandise on our website www.leuze.com under Contact & Support -> Repair Service & Returns:

To ensure quick and easy processing of your request, we will send you a returns order with the returns address in digital form.

**Note!**

Please use Chapter 10 as a master copy should servicing be required.

Cross the items in the "Measures" column which you have already examined, fill out the following address field and fax the pages together with your service contract to the fax number listed below.

Customer data (please complete)

Device type:	
Company:	
Contact person/department:	
Phone (direct dial):	
Fax:	
Street / no.:	
ZIP code / City:	
Country:	

Leuze Service fax number:

+49 7021 573 - 199

11 Type overview and accessories

11.1 Part number code

AMS 3xx / yyy H

Heating option	H =	With heating
Operating range	40	Max. operating range in m
	120	Max. operating range in m
	200	Max. operating range in m
	300	Max. operating range in m
	i =	Integrated fieldbus technology
Interface	00	RS 422/RS 232
	01	RS 485
	04	PROFIBUS DP / SSI
	08	TCP/IP
	35	CANopen
	38	EtherCAT
	48	PROFINET RT
	55	DeviceNet
	58	EtherNet/IP
84	Interbus	

AMS Absolute Measurement System

11.2 Overview of AMS 358/i types (EtherNet/IP)

Type designation	Description	Part no.
AMS 358/40	40m operating range, EtherNet/IP interface	50113725
AMS 358/120	120m operating range, EtherNet/IP interface	50113726
AMS 358/200	200m operating range, EtherNet/IP interface	50113727
AMS 358/300	300m operating range, EtherNet/IP interface	50113728
AMS 358/40 H	40m operating range, EtherNet/IP interface, integrated heating	50113729
AMS 358/120 H	120m operating range, EtherNet/IP interface, integrated heating	50113730
AMS 358/200 H	200m operating range, EtherNet/IP interface, integrated heating	50113731
AMS 358/300 H	300m operating range, EtherNet/IP interface, integrated heating	50113732

Table 11.1: Overview of AMS 358/i types

11.3 Overview of reflector types

Type designation	Description	Part no.
REF 4-A-150x150	Reflective tape, 150x150mm, self-adhesive	50141015
Reflective tape 200x200-S	Reflective tape, 200x200mm, self-adhesive	50104361
REF 4-A-300x300	Reflective tape, 300x300mm, self-adhesive	50141014
Reflective tape 500x500-S	Reflective tape, 500x500mm, self-adhesive	50104362
Reflective tape 914x914-S	Reflective tape, 914x914mm, self-adhesive	50108988
Reflective tape 200x200-M	Reflective tape, 200x200mm, affixed to carrier plate	50104364
Reflective tape 500x500-M	Reflective tape, 500x500mm, affixed to carrier plate	50104365
Reflective tape 914x914-M	Reflective tape, 914x914mm, affixed to carrier plate	50104366
Reflective tape 200x200-H	Reflective tape, 200 x 200mm, heated	50115020
Reflective tape 500x500-H	Reflective tape, 500 x 500mm, heated	50115021
Reflective tape 914x914-H	Reflective tape, 914 x 914mm, heated	50115022

Table 11.2: Overview of reflector types

11.4 Accessories

11.4.1 Accessories – Mounting bracket

Type designation	Description	Part no.
MW OMS/AMS 01	Mounting bracket for mounting AMS 358/ to horizontal surfaces	50107255

Table 11.3: Accessories – Mounting bracket

11.4.2 Accessories – Deflector unit

Type designation	Description	Part no.
US AMS 01	Deflector unit with integrated mounting bracket for AMS 358/ Variable 90° deflection of laser beam in different directions	50104479
US 1 OMS	Deflector unit without mounting bracket for simple 90° deflection of laser beam	50035630

Table 11.4: Accessories – Deflector unit

11.4.3 Accessories – M12 connector

Type designation	Description	Part no.
------------------	-------------	----------

Table 11.5: Accessories – M12 connector

S-M12A-ET	M12 connector, Ethernet, D-coded, BUS IN, BUS OUT	50112155
KDS ET M12/RJ45 W - 4P	Converter from M12 D-coded to RJ45 socket	50109832
KD 095-5A	M12 connector, A-coded socket, Power (PWR)	50020501

Table 11.5: Accessories – M12 connector

11.4.4 Accessories – Ready-made cables for voltage supply

Contact assignment/core color of PWR connection cable

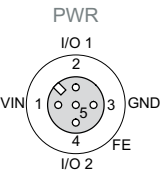
PWR connection cable (5-pin socket, A-coded)			
 <p>M12 socket (A-coded)</p>	Pin	Name	Core color
	1	VIN	Brown
	2	I/O 1	White
	3	GND	Blue
	4	I/O 2	Black
	5	FE	Gray
	Thread	FE	Bare

Technical data of the cables for voltage supply

Operating temperature range In idle state: -30°C ... +70°C
 In motion: -5°C ... +70°C

Material Sheathing: PVC

Bending radius > 50 mm

Order codes of the cables for voltage supply

Type designation	Description	Part no.
K-D M12A-5P-5m-PVC	M12 socket, A-coded, axial connector outlet, open cable end, cable length 5m	50104557
K-D M12A-5P-10m-PVC	M12 socket, A-coded, axial connector outlet, open cable end, cable length 10m	50104559

11.4.5 Accessories - Ready-made cables for EtherNet/IP

General

- Cable **KB ET...** for connecting to EtherNet/IP via M12 connector
- Standard cable available in lengths from 2 ... 30m
- Special cable on request.

Contact assignments M12 EtherNet/IP connection cable KB ET ...

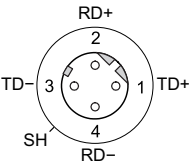
M12 EtherNet/IP connection cable (4-pin plug, D-coded, on both sides)			
EtherNet	Pin	Name	Core color
 <p>M12 connector (D-coded)</p>	1	TD+	Yellow
	2	RD+	White
	3	TD-	Orange
	4	RD-	Blue
	SH (thread)	FE	Bare

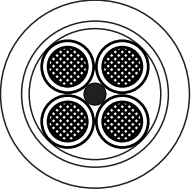
	Core colors
	WH
	YE
	BU OG
Conductor class: VDE 0295, EN 60228, IEC 60228 (Class 5)	

Accessory M12 EtherNet/IP connection cable, open cable end

Cable designation: KB ET - ... - SA

Accessory M12 EtherNet/IP connection cable with both-sided D-coded M12 connector

Cable designation: KB ET - ... - SSA

Accessory EtherNet/IP connection cable, M12-/RJ45

Cable designation: KB ET - ... - SA-RJ45

Notice for connecting the EtherNet/IP interface!

The entire interconnection cable must be shielded. The shielding connection must be at the same potential at both ends of the data line. This serves to prevent potential equalization currents over the shield and possible interference coupling through compensating currents. The signal lines must be stranded in pairs. Use CAT 5 cables for the connection.

Technical data of the EtherNet/IP connection cable

Operating temperature range In idle state: -50°C ... +80°C
In motion: -25°C ... +80°C
In motion: -25°C ... +60°C
(when used with drag chains)

Material Cable sheath: PUR (green), wire insulation: PE foam,
Free of halogens, silicone and PVC

Bending radius > 65 mm, suitable for drag chains
Bending cycles > 10⁶, perm. acceleration < 5 m/s²

Order codes for EtherNet/IP connection cables

Type designation	Description	Part no.
M12 connector for BUS IN, axial connector, open cable end		
KB ET - 1000 - SA	Cable length 1m	50106738
KB ET - 2000 - SA	Cable length 2m	50106739
KB ET - 5000 - SA	Cable length 5m	50106740
KB ET - 10000 - SA	Cable length 10m	50106741
KB ET - 15000 - SA	Cable length 15m	50106742
KB ET - 20000 - SA	Cable length 20m	50106743
KB ET - 25000 - SA	Cable length 25m	50106745
KB ET - 30000 - SA	Cable length 30m	50106746
M12 connector for BUS IN to RJ-45 connector		
KB ET - 1000 - SA-RJ45	Cable length 1m, cable 1:1, not crossed	50109879
KB ET - 2000 - SA-RJ45	Cable length 2m, cable 1:1, not crossed	50109880
KB ET - 5000 - SA-RJ45	Cable length 5m, cable 1:1, not crossed	50109881
KB ET - 10000 - SA-RJ45	Cable length 10m, cable 1:1, not crossed	50109882
KB ET - 15000 - SA-RJ45	Cable length 15m, cable 1:1, not crossed	50109883
KB ET - 20000 - SA-RJ45	Cable length 20m, cable 1:1, not crossed	50109884
KB ET - 25000 - SA-RJ45	Cable length 25m, cable 1:1, not crossed	50109885
KB ET - 30000 - SA-RJ45	Cable length 30m, cable 1:1, not crossed	50109886
M12 connector + M12 connector for BUS OUT to BUS IN		
KB ET - 1000 - SSA	Cable length 1m	50106898
KB ET - 2000 - SSA	Cable length 2m	50106899
KB ET - 5000 - SSA	Cable length 5m	50106900
KB ET - 10000 - SSA	Cable length 10m	50106901
KB ET - 15000 - SSA	Cable length 15m	50106902
KB ET - 20000 - SSA	Cable length 20m	50106903
KB ET - 25000 - SSA	Cable length 25m	50106904
KB ET - 30000 - SSA	Cable length 30m	50106905

12 Maintenance

12.1 General maintenance information

With normal use, the laser measurement system does not require any maintenance by the operator.

Cleaning

In the event of dust build-up or if the warning message (ATT) is displayed, clean the device with a soft cloth; use a cleaning agent (commercially available glass cleaner) if necessary. Also check the reflector for possible soiling.



Attention!

Do not use solvents and cleaning agents containing acetone. The use of such solvents can dull the reflector, the housing window and the display.

12.2 Repairs, servicing



Attention!

Access to or changes on the device, except where expressly described in this operating manual, is not authorized. The device must not be opened. Failure to comply will render the guarantee void. Warranted features cannot be guaranteed after the device has been opened.

Repairs to the device must only be carried out by the manufacturer.

 *Contact your Leuze distributor or service organization should repairs be required. The addresses can be found on the inside of the cover and on the back.*



Note!

When sending laser measurement systems to Leuze for repair, please provide an accurate description of the fault.

12.3 Disassembling, packing, disposing

Repacking

For later reuse, the device is to be packed so that it is protected.

Note!

Electrical scrap is a special waste product! Observe the locally applicable regulations regarding disposal of the product.

A	
Accessories	103
Accessories – Deflector unit	104
Accessories – Mounting bracket	104
Accessories – Ready-made cables	105
Accuracy	17
Activation for inputs	89
Activation for outputs	90
Activation of output (dynamic output)	91
Adapter (device class)	61
Addressing	58
Air humidity	18
Alarm flag	83
Alignment	23
B	
BootP	14
C	
Cleaning	108
Configuration consistency value	78
Configuring config assembly	16
Connections	
EtherNet/IP BUS IN	41
EtherNet/IP BUS OUT	42
PWR IN	41
Service	42
Contouring error calculation	17
Contrast	87
Control buttons	47
Control panel	43
D	
Declaration of Conformity	5
Definition of input/output	89
Deflector unit	
Maximum operating range	27
With integrated mounting bracket	27
Without mounting bracket	29
Deflector unit US 1 OMS	
Dimensioned drawing	29
Deflector unit US AMS 01	
Dimensioned drawing	28
Description of functions	6
Device type	77
DHCP	14
Diagnosis	97
Dimensioned drawing of AMS 3xxi	19
Direction Counting	80
Direction of movement	85
Display	43
E	
EDS file	61, 63
Detailed description	70
Electrical connection	40
Safety notices	40
Enter network address	59
EtherNet/IP device class	61
EtherNet/IP interface	56
Expanded diagnosis	98
Explanation of symbols	5
Explicit messages	56
Extended heating control	88
F	
Fast commissioning	12
Free resolution	85
Function assignment of hardware outputs	90
Function assignment of inputs	89
G	
General causes of errors	99
H	
Heartbeat interval	78
Heated reflectors	
Dimensioned drawing	34
Technical data	33
I	
Illumination	87
Implicit messages	56
Input function state	90
Installation	21
Interface errors	101
Interface info in display	44
Internal hardware error	44

L	
Language selection	87
Laser diode control	86
Laser diode status	86
LINK LED	46
M	
Main menu	
Device information	48
Language selection	48
Network information	48
Parameter	48
Service	48
Maintenance	108
Measurement range	17
Menus	
Language selection menu	53
Main menu	48
Parameter menu	49
Service menu	53
Mounting	22
With laser beam deflector unit	27
Mounting bracket (optional)	24
Movement status	85
N	
Name plates	21
NET LED	46
O	
Offset value	85
Operating principle	12
Operating range	103
Operating status - Direction counting	82
Operating temperature	18
Operating time	84
Operation	43, 54
Output function state	91
Output time	17
Overview of reflector types	104
P	
Package contents	21
Parallel mounting	25
Parameter enable	54, 55
Parameter menu	
EtherNet/IP	49
I/O	51
Other	52
Parameter handling	49
Position value	50
Password	87
Password protection	87
Plausibility error	43
Position error delay	92
Position error delay time	92
Position format	80
Position sensor type	80
Position status error delay	92
Position value	79
Position value in the case of failure	92
Prefailure message	43
Preset reset	85
Preset status	84
Preset teach	84
Preset toggle	84
Preset value	84
Product Code	77
Product Name	78
PWR LED	45
Q	
Quality assurance	5
R	
Received signal	44
Reflective tape	
Dimensioned drawing	32
Technical data	31
Reflector	30
Mounting	36
Pitch	39
Size	35
Type overview	35
Repair	108
Response time	17
Revision	77

S

Serial number 78
 Servicing 108
 State 78
 Status 77
 Status and measurement data - main menu . 48
 Status and warning messages 43
 Status indicator 43
 ATT 101
 ERR 101
 PLB 101
 TMP 101
 Status indicator – LSR 101
 Status indicators 44
 Status indicators in the display 101
 Status messages 97
 Storage 21
 Storage temperature 18
 Supply voltage 17
 Supported alarm 82
 Supported warnings 83
 Surface reflections 37
 Symbols 5

T

Technical data 17
 Dimensioned drawing 19
 General specifications 17
 Reflective tapes 30
 Temperature monitoring 43
 Topology 58
 Transfer data to the control 16
 Transport 21
 Troubleshooting 97
 Type overview 20, 103

U

Using explicit message services 16

V

Velocity error delay 93
 Velocity error delay time 93
 Velocity format 81
 Velocity free resolution 81
 Velocity in the case of failure 92
 Velocity limit value
 Direction selection 95

Release 94
 Switching type 95
 Velocity hysteresis 95
 Velocity limit value 95
 Velocity status error delay 93
 Velocity value 80
 Vendor ID 77

W

Warning flag 83
 Warnings 83

Level 1 ▲▼ : Selection	Level 2 ▲▼ : Selection ESC : Back	Level 3 ▲▼ : Selection ESC : Back	Level 4 ▲▼ : Selection ESC : Back	Level 5 ▲▼ : Selection ESC : Back	Selection/configuration option ▲▼ : Selection ↵ : Activate ESC : Back	Detailed information on		
Device information						Page 48		
Network information						Page 48		
Status and measurement data						Page 48		
Parameter	↵ Parameter handling	↵ Parameter enable			ON/OFF	Page 49		
		↵ Password	↵ Activate password		ON/OFF			
			↵ Password entry		For setting a four-digit numerical password			
		↵ Parameters to default		All parameters are reset to their factory settings				
	↵ EtherNet/IP	↵ Activation			ON/OFF	Page 49		
		↵ Ethernet interface	↵ Address		Address of the AMS 358/			
			↵ Gateway		Gateway for the AMS 358/			
			↵ Net mask		Net mask for the subnet of the AMS 358/			
			↵ DHCP activated		ON/OFF			
			↵ BootP activated		ON/OFF			
↵ Position value	↵ Unit			Metric/Inch	Page 50			
	↵ Counting direction			Positive/Negative				
	↵ Offset			Value input:				
	↵ Preset			Value input				
	↵ Error delay			ON/OFF				
	↵ Position value in the case of failure			Last valid value / zero				
	↵ Free resolution value			5 ...50000				
↵ I/O	↵ I/O 1	↵ Port configuration	↵ Switching input	↵ Function	No function/teach preset/laser ON/OFF	Page 51		
				↵ Activation	Low active/High active			
		↵ Switching output	↵ Function	Pos. limit value 1 / Pos. limit value 2 / Velocity / Intensity (ATT) / Temp. (TMP) / Laser (LSR) / Plausibility (PLB) / Hardware (ERR)				
			↵ Activation	Low active/High active				
			↵ I/O 2	↵ Port configuration	↵ Switching input		↵ Function	No function/teach preset/laser ON/OFF
							↵ Activation	Low active/High active
	↵ Switching output	↵ Function	Pos. limit value 1 / Pos. limit value 2 / Velocity / Intensity (ATT) / Temp. (TMP) / Laser (LSR) / Plausibility (PLB) / Hardware (ERR)					
		↵ Activation	Low active/High active					
		↵ Limit values	↵ Upper pos. limit 1	↵ Activation	ON/OFF			
				↵ Limit value input	Value input in mm or inch/100			
			↵ Lower pos. limit 1	↵ Activation	ON/OFF			
		↵ Limit value input	Value input in mm or inch/100					
	↵ Upper pos. limit 2	↵ Activation	ON/OFF					
	↵ Limit value input	Value input in mm or inch/100						

		⊞ Lower pos. limit 2	⊞ Activation	ON/OFF	
			⊞ Limit value input	Value input in mm or inch/100	
⊞ Other	⊞ Heating control			Standard (heating: on < 10°C, off > 15°C) / Extended (heating: on < 30°C, off > 35°C)	Page 52
	⊞ Display background			10 minutes/ON	
	⊞ Display contrast			Weak/Medium/Strong	
	⊞ Service RS232	⊞ Baud rate		57.6kbit/s / 115.2kbit/s	
		⊞ Format		8,e,1 / 8,n,1	
Language selection ⊞				Deutsch / English / Español / Français / Italiano	Page 53
Service	⊞ Status messages			Number of readings, reading gates, reading rate / non-reading rate etc.	Page 53
	⊞ Diagnosis			Only for use by Leuze personnel for service purposes	
	⊞ Expanded diagnosis			Only for use by Leuze personnel for service purposes	